

FRONTIER FORTS OF KELNORE

Judges Guild

By DAVE SERING

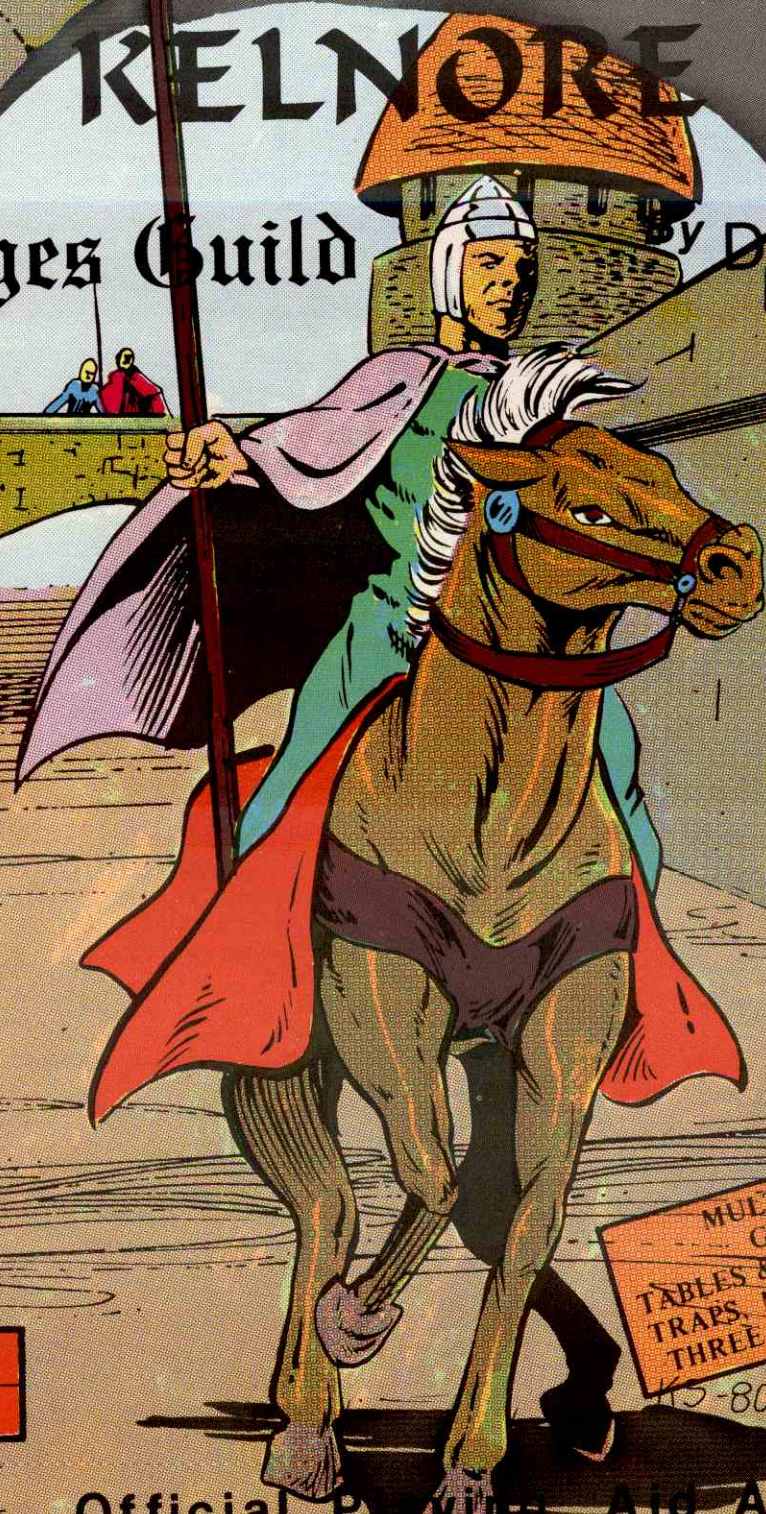

MULTI-LEVEL ADVENTURE
GENERATION SYSTEM
TABLES & CHARTS TO BUILD SCENARIO
TRAPS, MONSTERS, TREASURES, MAPS
THREE COMPLETE EXAMPLES GIVEN

71
\$3

Official Product and Approved For
DUNGEONS & DRAGONS™

Judges Guild

Treasure

Vault



APPROVED FOR USE WITH TRAVELLER tm

JG 75	Traveller Referee Screen	\$2.50
JG 78	Traveller Log Book	\$3.00
JG 89	Starship & Spacecraft for Traveller	\$5.50
JG 105	Dra'k'ne Station	\$4.95

APPROVED FOR USE WITH AD&D tm

JG 87	Character Codex	\$4.50
JG 88	Dark Tower	\$5.50
JG 109	Operation Ogre	\$3.25
JG 114	Maltese Clue	\$4.00
JG 117	Temple of Ra Accursed by Set	\$2.00
JG 124	Escape From Astigar's Lair	\$2.00
JG 190	The Treasure Vaults of Lindoran	\$4.00
JG 210	Inferno	\$5.98
JG 260	Portals of Torsh	\$3.98

APPROVED FOR USE WITH RUNEQUEST GATEWAY tm

JG 107	Broken Tree Inn	\$4.00
JG 116	The HellPits of NightFang	\$3.00
JG 170	Runequest Shield	\$2.50
JG 220	Legendary Duck Tower	\$5.98
JG 310	City of Lei Tabor	\$7.98

THE JUDGES GUILD JOURNAL

\$2.80 per Issue
Back Issues Available

THE DUNGEONEER

\$2.80 per Issue
Back Issues Available

JG 73	The Dungeoneer Compendium of 1 - 6	\$2.50
-------	------------------------------------	-------	--------

JG 37	First Fantasy Campaign	\$7.98
JG 46x4	Wilderlands Hex Sheets	\$3.00
JG 66	Sea Steeds & Wave Riders	\$6.50
JG 68	War Cry and Battle Lust	\$4.00
JG 69	Flotilla One	\$5.00
JG 96	Treasury of Archaic Names	\$4.95
JG 240	The Fantasy Cartographer's Field Book	\$3.98
JG 250	C & S Shield	\$3.00

APPROVED FOR USE WITH D&D tm

JG 2	Dungeon Tac Cards	\$3.95
JG 14	Ready Ref Book	\$2.99
JG 27	Tegel Manor	\$4.50
JG 28	Judges Shield	\$1.98
JG 34	Modron	\$3.50
JG 36	Character Chronicle Cards	\$1.98
JG 47	Campaign Hexagon System	\$2.50
JG 48	Wilderlands of High Fantasy	\$8.50
JG 52	Thieves of Badabaskor	\$3.00
JG 55	GenCon IX Dungeon	\$3.50
JG 59	Village Book I	\$2.75
JG 60	Castle Book I	\$2.75
JG 61	Island Book I	\$2.75
JG 62	City State of the Invincible Overlord	\$8.00
JG 63	Citadel of Fire	\$3.00
JG 67	Fantastic Wilderlands Beyond	\$8.00
JG 71	Frontier Forts of Kelnore	\$3.00
JG 76	Dragon Crown	\$1.75
JG 80	Of Skulls and Scrapfaggot Green	\$4.50
JG 92	Wilderlands of the Magic Realm	\$8.50
JG 93	Under the Storm Giant's Castle	\$3.00
JG 95	Survival of the Fittest	\$3.50
JG 102	Caverns of Thracia	\$6.50
JG 104	Village Book II	\$3.00
JG 108	Verbosh	\$6.50
JG 111	Mines of Custalcon	\$3.95
JG 113	Book of Treasure Maps	\$3.95
JG 118	Sword of Hope	\$3.00
JG 119	Tower of Ulission	\$3.00
JG 150	City State of the World Emperor	\$12.00
JG 270	Spies of Lightelf	\$4.95

Are these other fine products available from your Dealer?

If not, ask why and have him contact us for full details.

Judges Guild, Incorporated, R. R. 8, Box 9, 1221 N. Sunnyside Road, Decatur, IL. 62526

FRONTIER FORTS OF KELNORE



Judges Guild

By DAVE SERING

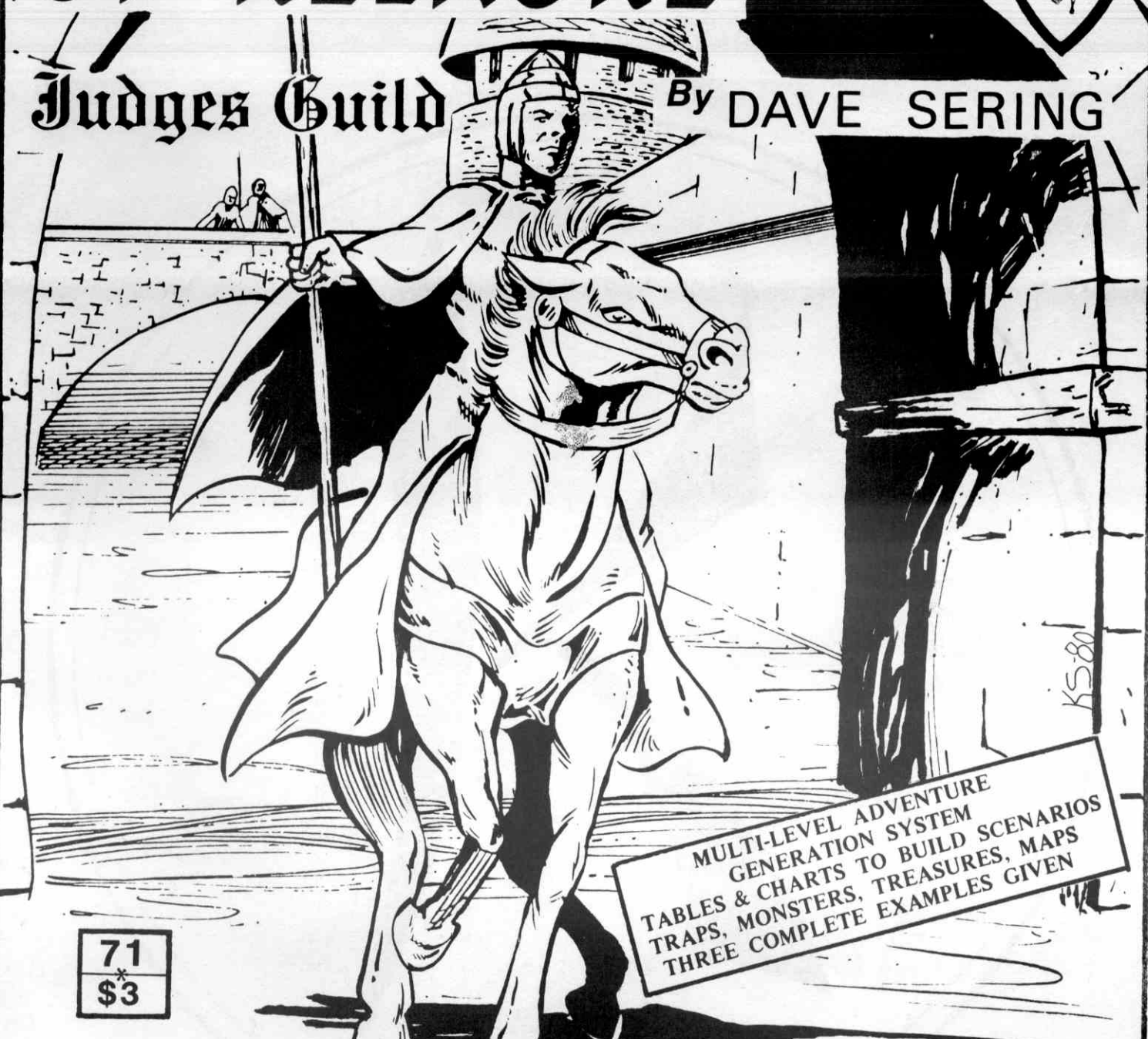

71
\$3

MULTI-LEVEL ADVENTURE
GENERATION SYSTEM
TABLES & CHARTS TO BUILD SCENARIOS
TRAPS, MONSTERS, TREASURES, MAPS
THREE COMPLETE EXAMPLES GIVEN

Official Playing Aid Approved For
DUNGEONS & DRAGONS™

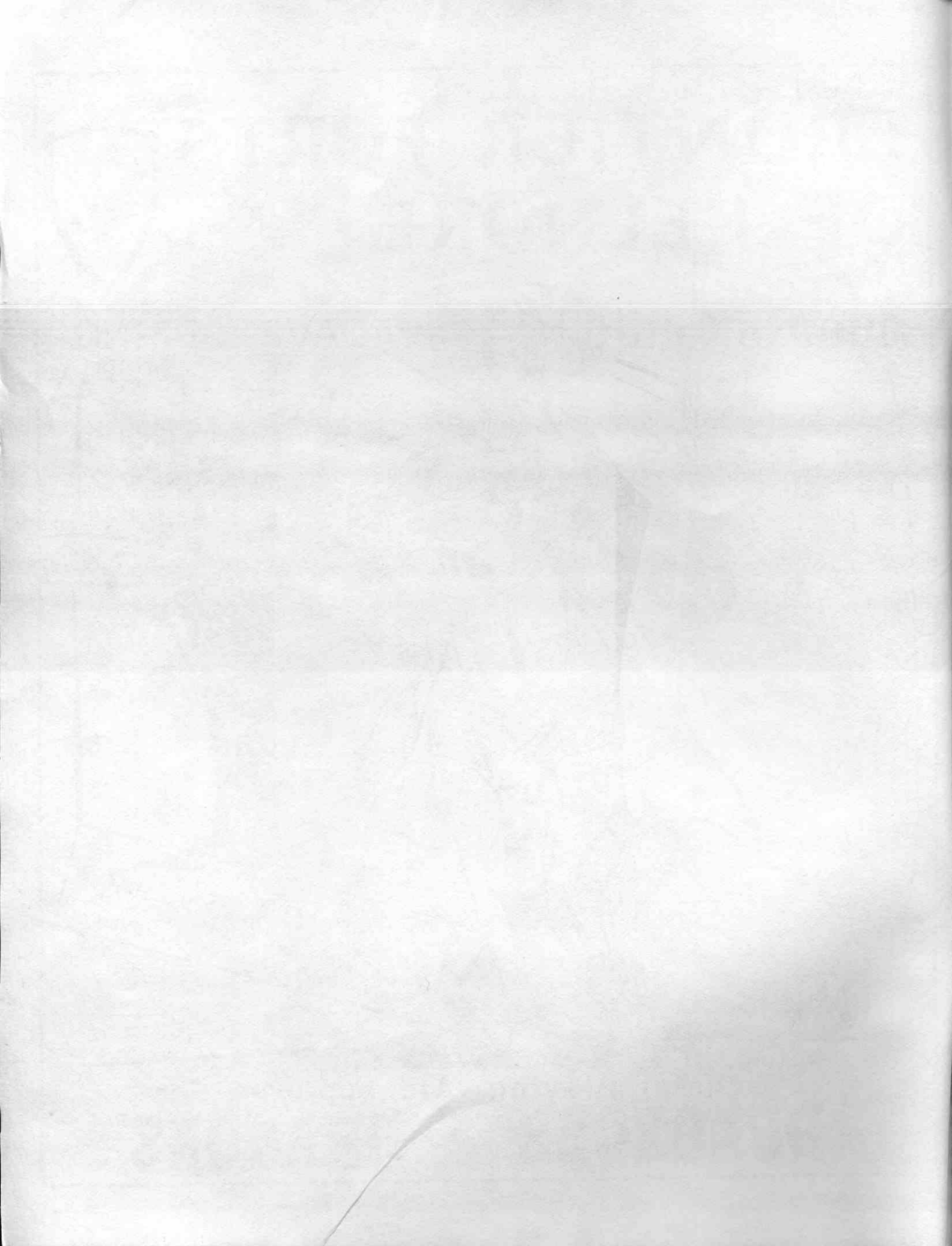

Frontier Forts Of Kelnore

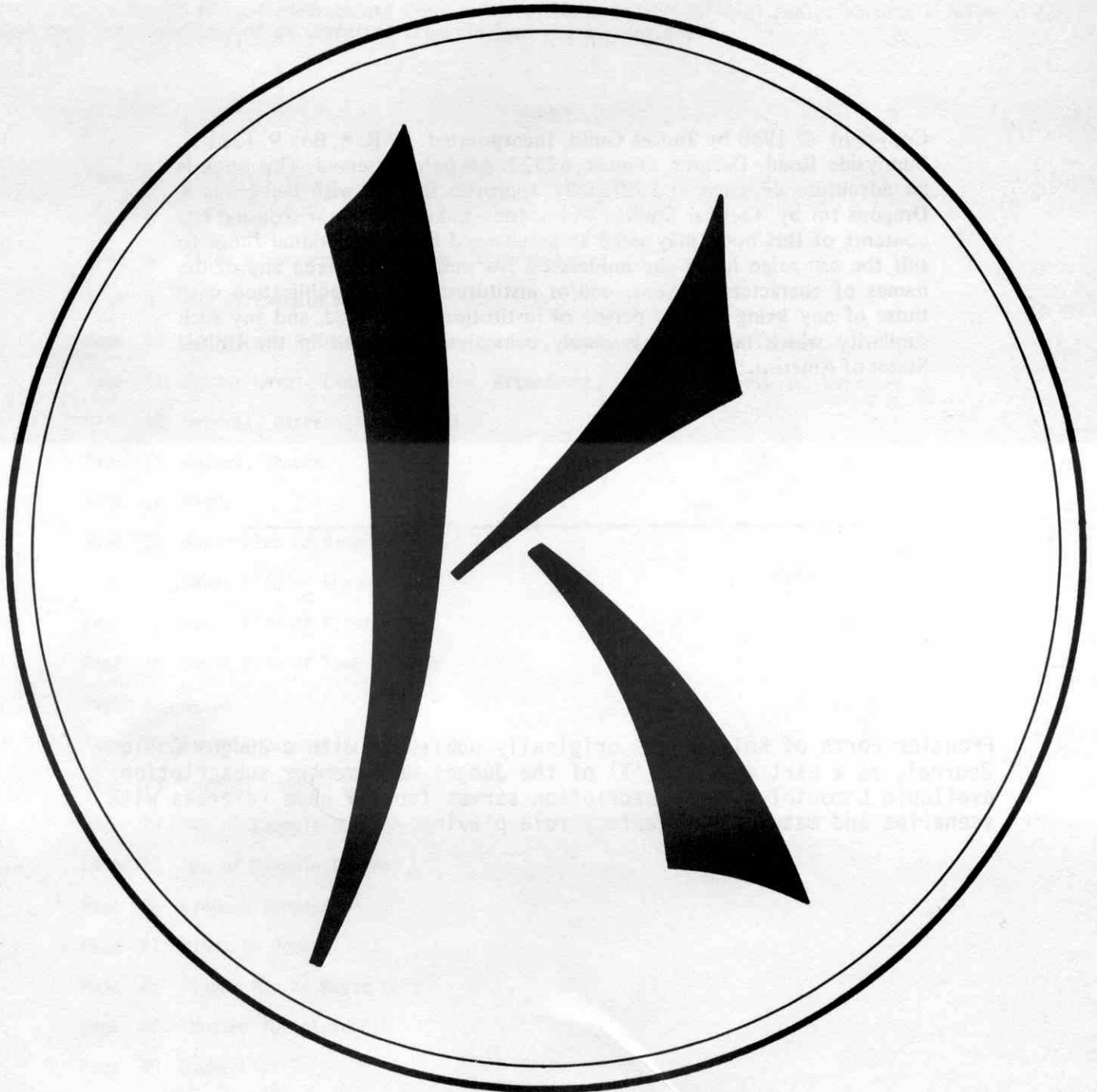

By Dave Sering

Illustrated by Dave Sering and Paul Jaquays

Copyright © 1980 by **Judges Guild, Incorporated**, R. R. 8, Box 9, 1221 N. Sunnyside Road, Decatur, Illinois 62522. All rights reserved. This book is an adventure designed and officially approved for use with **Dungeons & Dragons tm** by Tactical Studies Rules, Inc., Lake Geneva, Wisconsin. The contents of this book may need to be changed by the individual Judge to suit the campaign he or she moderates. No similarity between any of the names of characters, persons, and/or institutions in this publication with those of any living or dead person or institution is intended, and any such similarity which may exist is purely coincidental. Printed in the United States of America.



Frontier Forts of Kelnore was originally published with a Judges Guild Journal, as a part of issue 'T' of the Judges Guildmember subscription; available bimonthly, the subscription serves fantasy game referees with scenarios and material on fantasy role playing.

INTRODUCTION

The purpose of this installment is to provide the Judge with a short, two to three hour adventure in an easily organized and moderated form. Every time the installment is utilized, a different set-up occurs. Each time the physical arrangement of the fort ranges from slightly different to wildly different. Each time the intrepid party has only a general knowledge of the layout of the old fort, knowing only what specifics the Judge tells them as they encounter. The Judge must set the scene of each adventure. This book is an adventure generating system. Three complete examples of adventures are given, but an almost infinite number of variations are possible. The Judge is provided with a framework but must supply the imagination and drive to make the adventure work. The system provides for a graduated level of opposition to match any level of adventure party. Use of all the Optional tables permits a Judge to generate a detailed dungeon adventure including specifics of room contents and traps. Use of parts of the Optional tables permits a Judge to detail just those portions of an adventure scenario that are appropriate.

INDEX

Page 5	Introduction
Page 6	Forts
Page 8	Sites & Surroundings, Ruins, Alterations
Page 9	Map of Example Dungeon A
Page 10	Additions, Principal Creature/Leader, Random Location, Alignment
Page 11	Leader Level, Leader Vocation, Attendants, Retainers, Servants, Warriors
Page 12	General, Disrepair, Monster
Page 13	Animal, Insect
Page 14	Finds
Page 15	Basic Plan of Basement Level
Page 16	Basic Plan of Ground Level
Page 17	Basic Plan of First Floor
Page 18	Basic Plan of Tower Floors
Page 19	Traps
Page 20	Example Dungeon A
Page 23	Example Dungeon B
Page 24	Map of Example Dungeon B
Page 25	Map of Example Dungeon C
Page 26	Example Dungeon C
Page 27	Hints to Judges
Page 28	Player Map of Basic Fort
Page 29	"Muster for Plunder!"
Page 30	Booty List

FORTS

In the Elder Days once stretched the Kingdom of Kelnore for many leagues across the land. To guard its far-flung frontiers, the Kings of Kelnore built a series of forts surrounding the borders. The King's Master Mason of the time had a great fear of the "irregular." And so with his supervision, the serfs and peasants labored to make each fort exactly like every other. From these forts, held by companies of professional soldiers, cavalry patrols kept a close watch on the surrounding countryside. For several centuries, the Army of Kelnore held the frontiers inviolate against marauding barbarians and hostile powers. In time internal dissention broke out and contending factions plunged the kingdom into civil war. As the frontier troops were drawn into the struggle, the frontier forts were abandoned one by one. With the border undefended and the center in chaos, the kingdom was soon overrun by a horde of tribesmen, indiscriminately pillaging and burning. Several centuries later, the Kingdom of Kelnore is known only from the scrolls of historians and by legends. Yet many of the border forts still exist, some only in tumbled ruins, others occupied by various beings down through the years.

Though originally built exactly alike, later garrison commanders made certain changes on their own. Also, after being ruined and abandoned, the forts have been rebuilt or altered by subsequent occupants. Thus, each fort is no longer exactly like all the others. The degree to which the structure of the buildings have deteriorated is dependent upon how long they have been exposed to the weather and what damage was done to the buildings when the troops left. Subsequent alterations, additions, and repairs are determined by the skills, numbers, and length of stay of succeeding occupiers.

The Judge may have a specific site for this adventure in the context of a campaign or may roll a location on Table 1. Site and Surroundings. An approximate history can be generated on the following table which also gives the corresponding number of rolls on the Ruins, Alterations, and Additions Tables.

Table 2:	Ruins (Table 3)	Alterations (Table 4)	Additions (Table 5)
1. Ancient Ruin	4	1	1
2. Abandoned	3	1	1
3. Deserted	2	1	2
4. Occupied	1	2	2
5. Outpost	-	2	3
6. Stronghold	-	3	3

The plans of the basic fort are given on pages 15 through 18. They may be removed from this booklet by gently prying the ends of the staples up and carefully lifting the double page free of the rest of the book. Press the staples back down again. The plans may then be placed in plastic page protectors, which will allow the Judge to keep track of the specific modifications for each adventure by grease pencil. Each of the small sample dungeons has a reduced version of the plans with the appropriate modifications overprinted in color.

Now that the physical setting has been determined, the Judge must next produce the Principal Creature/Leader involved with the fort in this adventure. The primary consideration at this point in a random encounter is the experience level and number of people in the adventure party. The Judge must choose the opposition very carefully depending upon whether he/she wishes to give the party a light "work-out" or an ultimate challenge. As an aid in decision making, note that Ancient Ruins are occupied by a single very strong creature with all but the main chamber empty. Abandoned forts contain several moderately powerful creatures with most other chambers empty (1-4 empty, 5-6 occupied) and might have the lesser rooms infested with vermin. Deserted structures have moderate numbers of less powerful creatures with half of the rooms being empty and a high incidence of minor "nuisance critters".

Occupied forts are inhabited by a Leader character and some subordinates with one third of the chambers empty. Only a few vermin would be present in the empty rooms. Outposts are an important part of a larger organization and would have only 1 out of 6 chambers empty and would be unlikely to have minor creatures occupying them. Strongholds would be the central feature of a Leader and subordinates with only perhaps one room in 20 being temporarily empty. If the Judge does not have a specific chamber for the Principal Creature/Leader to occupy, roll on the Random Location Chart, Table 7.

In many instances the Principal Creature will have a number of subordinate creatures under control or in association. The Judge may assign a specific type and number of these subordinates based upon the number and level of the adventure party. Alternately the Judge may roll on the appropriate section of Table (17) Monsters and consider whatever appears to be controlled by the Principal Creature. Principal Creatures usually have an assigned alignment.

Leaders, especially man-types, will have subsidiary followers in the form of Henchmen and Hirelings. The alignment of the Leader and followers, if not set by the Judge in reference to the campaign set up may be determined by rolling on Table 8 Alignment. Since man-types have many options of behavior, vocation, and class, the next series of tables determines what Level (Table 9), the number of Henchmen and Hirelings, in attendance on, and the Vocation of (Table 10) the Principal Leader. Some vocations may conflict with alignments as rolled. The Judge may roll again or adjust to suit. If specific occupations for followers are required, roll on Tables 11 Attendants, 12 Retainers, or 14 Warriors for Henchmen and on Tables 13 Servants and 14 Warriors for Hirelings.

As an additional aid to Judges are included a series of Optional Tables for detailing the various rooms and chambers as and when the need arises. Table 15 is a General Table, determining the status and occupancy of a room. Empty means no further rolls. Disrepair indicates one roll on Table 16 Disrepair. Treasure indicates that the Judge is to insert an item or items of value appropriate to the level of the adventure party and the opposition. Monster indicates that the Judge is to roll on one of the sections of Table 17; Section A if the party is First through Third Level, Section B if the party is Fourth through Sixth Level, and Section C if the party is Seventh through Ninth Level. Animal and Insect indicate rolls on Tables 18 and 19. These last two serve as nuisance items to high level characters and might in some circumstances be disregarded by Judges to speed up play. Finds indicates a roll on Table 20, with subsequent rolls on the accompanying charts to obtain a specific artifact. These artifacts may be used by the Judge in varying ways, as litter under foot, as encounters, or as treasures. Traps indicates a roll on Table 21 with subsequent rolls on the accompanying charts to delineate the type and the specific amount of damage done.

As an alternative to using Table 6 Principal Creature/Leader, the Judge may utilize the appropriate section of Table 17 to produce the major inhabitant or threat of the adventure.

Three sample dungeons are provided. The first is given in greater detail to assist Judges in the conversion of the data from the tables to adventure scenarios. Remember that these are only one way of interpreting the rolls of the dice, each Judge giving a different flavor to the same scenario.

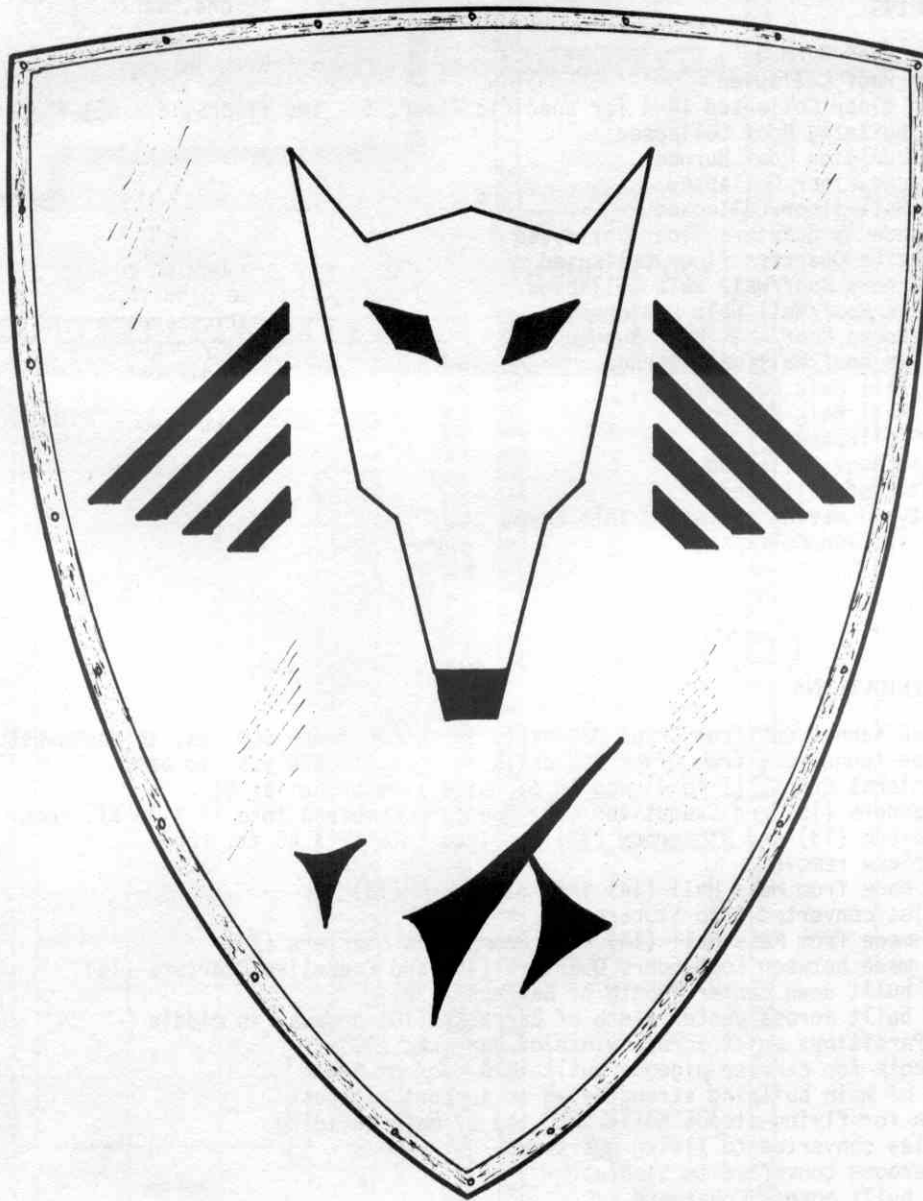

Table 1: SITE and SURROUNDINGS

1. River Ford
2. Bluff Edge
3. Lake Side
4. Riverbank
5. Island
6. Seashore
7. Hilltop
8. Forest Edge
9. Hill Side
10. Flat Plain
11. Rocky Eminence
12. Dell
13. Harbor
14. Farmland
15. Small Village
16. Mountain Pass
17. Desert
18. Swamp Edge
19. Oasis
20. River Mouth

Table 3: RUINS

1. Tower roof Burned
2. Tower roof Collapsed
3. Tower floor Collapsed (1-4 for specific floor, 5 - two floors, 6 - all floors)
4. Main Building Roof Collapsed
5. Main Building Roof Burned
6. Barracks floor Collapsed
7. Mess Hall floor Collapsed
8. Commander's Quarters floor Collapsed
9. Executive Quarters floor Collapsed
10. Storerooms Roof/Wall Walk Collapsed
11. Stables Roof/Wall Walk Collapsed
12. Storerooms Roof/Wall Walk Burned
13. Stables Roof/Wall Walk Burned
14. Gate/Wall Walk Collapsed
15. Gate/Wall Walk Burned
16. Well Collapsed
17. Cellar Roof Collapsed
18. Crypt Roof Collapsed
19. Courtyard paving collapsed into Crypt
20. Wall section collapsed

Table 4: ALTERATIONS

1. Escape tunnel dug from Crypt 02, exits in tuined tower 600 yds. to southwest
2. Escape tunnel dug from Crypt 05, exits in rockpile 200 yds. to east
3. Additional Crypts (1 to 4) dug on opposite side of Cellar 01
4. Commanders (15) and Executives (16) Quarters combined into 15 X 30 ft. room
5. Storeroom (13) and Storeroom (12) combined into 12 X 45 ft. room
6. Fireplace removed
7. Door made from Mess Hall (14) into Storeroom (13)
8. Stables converted into Storerooms
9. Door made from Mess Hall (14) into Commanders Quarters (15)
10. Door made between Commanders Quarters (15) and Executive Quarters (16)
11. Wall built down center length of Barracks (18)
12. Wall built across center width of Barracks (18) doorway in middle
13. Two Partitions built across width of Barracks (18)
14. Dovecote for carrier pigeons built into roof of tower
15. Roof of main building strengthened to support catapult
16. Perch for flying steeds built onto top of main building
17. Stables converted to living quarters
18. Storerooms converted to Stables
19. Wall built across Courtyard
20. Stables converted to Storerooms

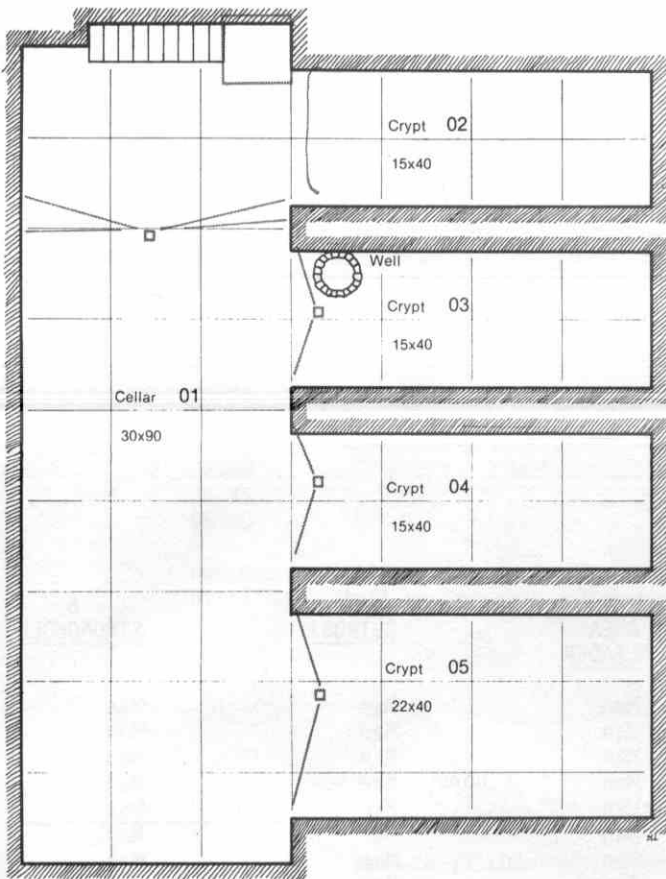

Basement Level

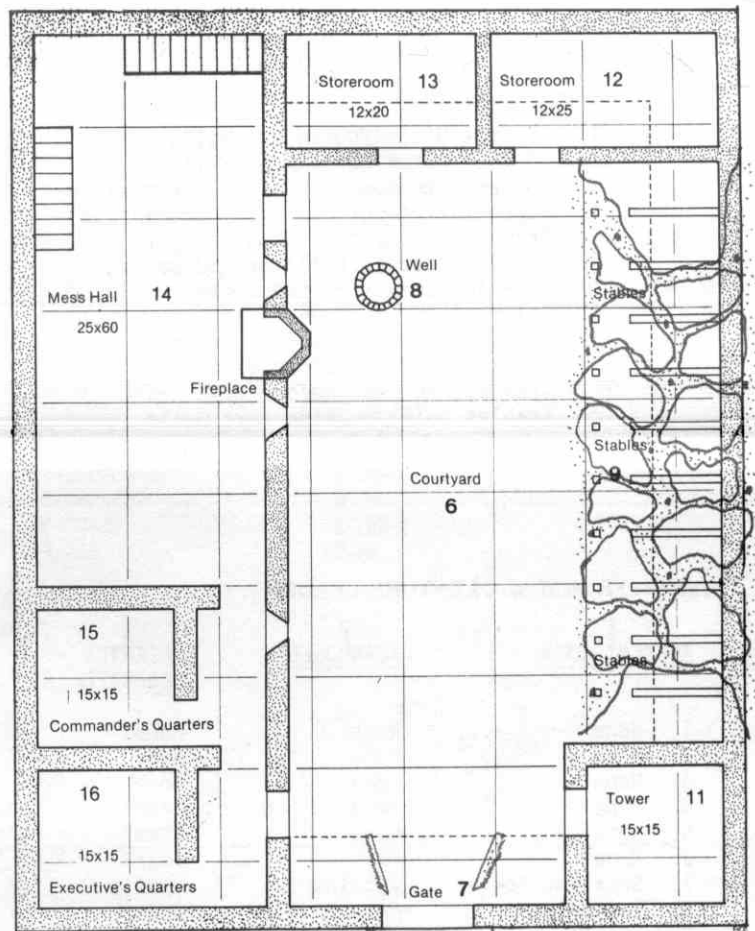

Ground Floor

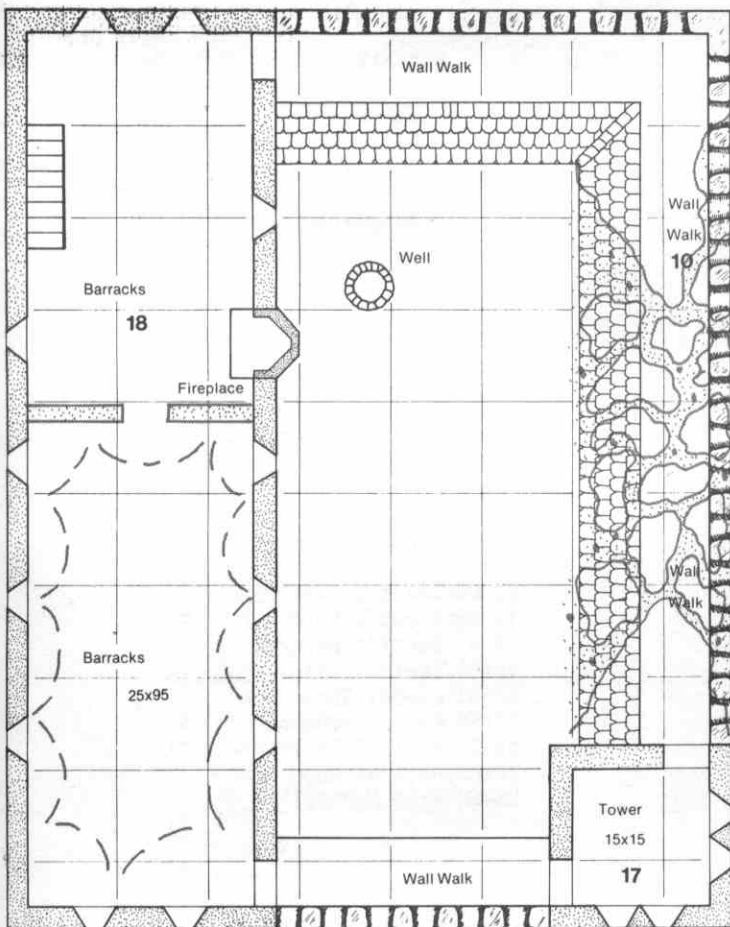

First Floor

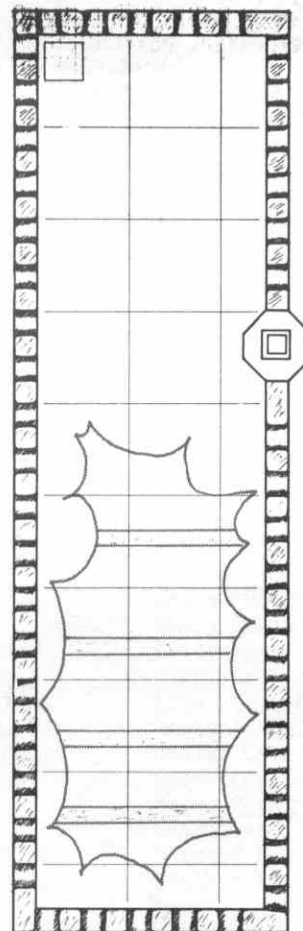

9. Tower Floors

*Example
Dungeon
A*

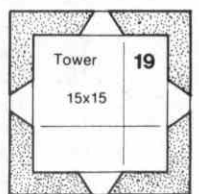
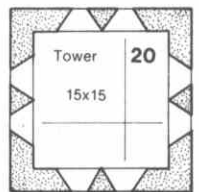

Table 5: ADDITIONS

1. 5 foot Ditch dug around walls
2. 10 foot Ditch dug around walls
3. Wooden watchtower on nearby prominence
4. Stone watchtower on nearby prominence
5. Drawbridge built in front of gate
6. Wooden stockade built around walls
7. Pits and stakes placed around walls
8. Caltrops sown around walls
9. Abatis placed at base of walls
10. Cheval-de-frise before gate
11. Trap pit in road before gate
12. Stables built outside fort walls

Table 6: PRINCIPAL CREATURE/LEADER

1 <u>ANCIENT RUIN</u>	2 <u>ABANDONED</u>	3 <u>RECENTLY DESERTED</u>	4 <u>AREA LEADER</u>	5 <u>OUTPOST</u>	6 <u>STRONGHOLD</u>
1. None	None	None	Man	Man	Man
2. None	None	None	Man	Man	Man
3. None	None	None	Man	Man	Man
4. None	None	Hermit	Man	Man	Man
5. None	None	Gnome	Man	Man	Man
6. None	Hermit	Dwarf	Man	Man	Man
7. Groaning Spirit	Goblins	Goblin	Man	Man	Man
8. Lamia	Orc	Orc	Gnome	Man	Man
9. Ghast	Hobgoblin	Half Orc	Goblin	Man	Man
10. Naga	Kobold	Half-Elf	Orc	Man	Man
11. Wight	Ogre	Elf	Half-Orc	Orc	Gnome
12. Wraith	Giant Slug	Pixie	Dwarf	Half-Orc	Orc
13. Shadow	Pseudo-Dragon	Brownies	Elf	Orc	Half Orc
14. Medusae	Ettin	Leprechaun	Halfling	Gnoll	Orc
15. Dragon	Doppelganger	Werebear	Gnome	Halfling	Halfling
16. Wizard	Jackalwere	Troll	Half-Elven	Elf	Elf
17. Spectre	Hydra	Werewolf	Gnoll	Half-Elf	Half-Elf
18. Ghosts	Wererats	Wereboar	Mind Flayer	Bugbear	Grey Elf
19. Vampire	Weretigers	Griffon	Balrog	Gray Elf	Dwarf
20. Liche	Ogre Mage	Harpy	Hobgoblin	Hobgoblin	Special

Table 7: RANDOM LOCATION

1. Cellar
2. Crypt
3. Crypt
4. Crypt
5. Crypt
6. Courtyard
7. Gate
8. Well
9. Stables
10. Wall Walk
11. Tower
12. Storeroom
13. Storeroom
14. Mess Hall
15. Commanders Quarters
16. Executives Quarters
17. Tower
18. Barracks
19. Tower
20. Tower

Table 8: ALIGNMENT

- 01-09 Chaotic Evil
- 10-19 Chaotic Good
- 20-31 Chaotic Neutral
- 32-41 Lawful Evil
- 42-51 Lawful Good
- 52-63 Lawful Neutral
- 64-75 Neutral Evil
- 76-87 Neutral Good
- 88-00 True Neutral

Table 9: LEADER LEVEL

	LEADER LEVEL	HENCHMEN	HIRELINGS
01-05	3	2-D4	3-D6
06-15	4	2-D4+2	3-D6+2
16-25	5	3-D4	4-D6
26-35	6	3-D4+2	4-D6+2
36-45	7	4-D4	5-D6
46-60	8	4-D4+2	5-D6+2
61-75	9	5-D4	6-D6
76-80	10	5-D4+2	6-D6+2
81-83	11	6-D4	7-D6
84-86	12	6-D4+2	7-D6+2
87-89	13	7-D4	8-D6
90-91	14	7-D4+2	8-D6+2
92-93	15	8-D4	9-D6
94-95	16	8-D4+2	9-D6+2
96-00	17	9-D4	10-D6

Henchmen - roll on Attendants, Retainers, & Warriors Tables.
 Hirelings - roll on Servants & Warriors Tables

Table 10: LEADER VOCATION

- | | |
|---------------|-----------------|
| 1. Fighter | 11. Monk |
| 2. Fighter | 12. Thief |
| 3. Fighter | 13. Magic User |
| 4. Fighter | 14. Illusionist |
| 5. Magic User | 15. Assassin |
| 6. Magic User | 16. Cleric |
| 7. Thief | 17. Sage |
| 8. Palatin | 18. Alchemist |
| 9. Cleric | 19. Bard |
| 10. Cleric | 20. Spy |

Table 11:

ATTENDANTS

1. Secretary
2. Clerk
3. Agent
4. Mate
5. Servitor
6. Messenger
7. Neighbor
8. Patron
9. Crony
10. Bodyguard
11. Champion
12. Assistant
13. Tumbler
14. Poet
15. Acquaintance
16. Ally
17. Consort
18. Courtier
19. Sycophant
20. Jester

Table 12:

RETAINERS

- Armsman
- Liegeman
- Chamberlain
- Squire
- Steward
- Huntsman
- Thane
- Sage
- Librarian
- Scribe
- Alchemist
- Agent
- Bailiff
- Sheriff
- Artist
- Soothsayer
- Bard
- Cleric
- Kinsman
- Comerad

Table 13:

SERVANTS

- Menial
- Page
- Waiter
- Butler
- Livery
- Footman
- Valet
- Groom
- Chaperone
- Housemaid
- Handmaiden
- Nursemaid
- Chambermaid
- Scullion
- Cook
- Guard
- Harem Girl
- Major-Domo
- Almoner
- Falconer

Table 14:

WARRIORS

- Light Foot Spearman
- Light Foot Bowman
- Light Foot Swordsman
- Medium Foot Spearman
- Medium Foot Bowman
- Medium Foot Swordsman
- Light Cavalry Lancer
- Light Cavalry Bowman
- Medium Cavalry Lancer
- Medium Cavalry Bowman
- Heavy Cavalry Lancer
- Heavy Cavalry Bowman
- Guardsman
- Mounted Guardsman
- Blacksmith
- Armorer
- Engineer

Table 15: GENERAL TABLE

1. Empty
2. Empty & Disrepair
3. Treasure & Trap
4. Monsters & Treasure
5. Treasure
6. Monster & Trap
7. Insect
8. Disrepair & Find
9. Find & Trap
10. Monster
11. Insect, Find & Disrepair
12. Insect & Trap
13. Insect & Disrepair
14. Animal
15. Animal & Treasure
16. Animal & Disrepair
17. Monster & Trap
18. Monster & Disrepair
19. Treasure & Trap
20. Treasure & Disrepair

Table 16: DISREPAIR

1. Crumbled Wall
2. Cracked Wall
3. Disfigured Wall
4. Collapsed Wall
5. Crumbling Ceiling
6. Cracked Ceiling
7. Collapsed Ceiling
8. Disfigured Floor
9. Cracked Floor
10. Collapsed Floor

Table 17: MONSTER

Section A	Section B	Section C
1. Kobolds (3-D4)	1. Doppelganger (2-D4)	1. Griffon (D4)
2. Orcs (2-D4)	2. Gargoyle (D4)	2. Spectre (D4)
3. Skeletons (D6)	3. Ghast (D6)	3. Xorn (D4)
4. Stirges (2-D4)	4. Ogre Mage (D6)	4. Wyvern (D4)
5. Adepts (D4)	5. OwlBear (D4)	5. Mummy (D4)
6. Gelatinous Cube (1)	6. Shadow (2-D4)	6. Minotaur (D4)
7. Hobgoblins (2-D4)	7. Brown Bear (D4)	7. Rakshasha (1)
8. Ghouls (D4)	8. Black Pudding (D4)	8. Beholder (1)
9. Piercers (D6)	9. Cockatrice (D4)	9. Gorgon (D4)
10. Carrion Crawler (1)	10. Hell Hound (2-D4)	10. Umber Hulk (D4)
11. Bugbears (2-D4)	11. Giant Hyena (2-D4)	11. Trapper (1)
12. Ogres (D4)	12. Su-Monster (D8)	12. Lurker Above (1)
13. Troglodyte (D6)	13. Tiger (D4)	13. Night Hag (1)
14. Pseudo-Dragon (D6)	14. Basilisk (D4)	14. Chimera (1)
15. Wererats (D4)	15. Cave Bear (D4)	15. Bulette (1)
16. Shriekers (D6)	16. Displacer Beast (2-D4)	16. Efreeti (1)
17. Ochre Jelly (1)	17. Leucrotta (D4)	17. Ettin (1)
18. Axe Beak (D4)	18. Manicore (D4)	18. Flesh Golem (1)
19. Baboon (6-D8)	19. Medusa (D4)	19. Purple Worm (D4)
20. Rust Monster (1)	20. Troll (D6)	20. Harpies (D6)

(Number Appearing)

Table 18: ANIMAL

1. Lion
2. Jackal
3. Ape
4. Baboon
5. Jaguar
6. Leopard
7. Wolves
8. Tiger
9. Bears
10. Wolverine
11. Lizard
12. Hyenas
13. Coyote
14. Puma
15. Bats
16. Wildcat
17. Rats
18. Panther
19. Gorilla
20. Snake

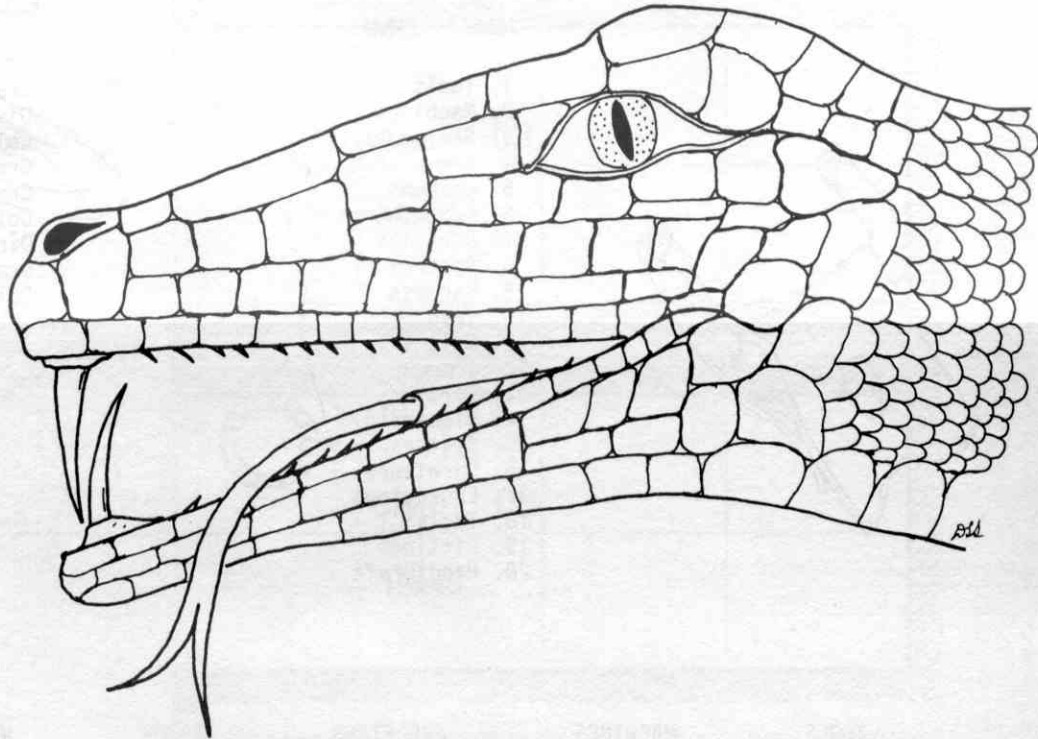

Table 19: INSECT

1. G. Wasp
2. Locust
3. Dragon Flies
4. Tick
5. Beetle
6. Mantis
7. Cockroach
8. Flies
9. Spider
10. G. Ants
11. Lice
12. Scorpions
13. Bees
14. Centipedes
15. Crickets
16. Fleas
17. Stink Bugs
18. Gnats
19. Butterflies
20. G. Slug

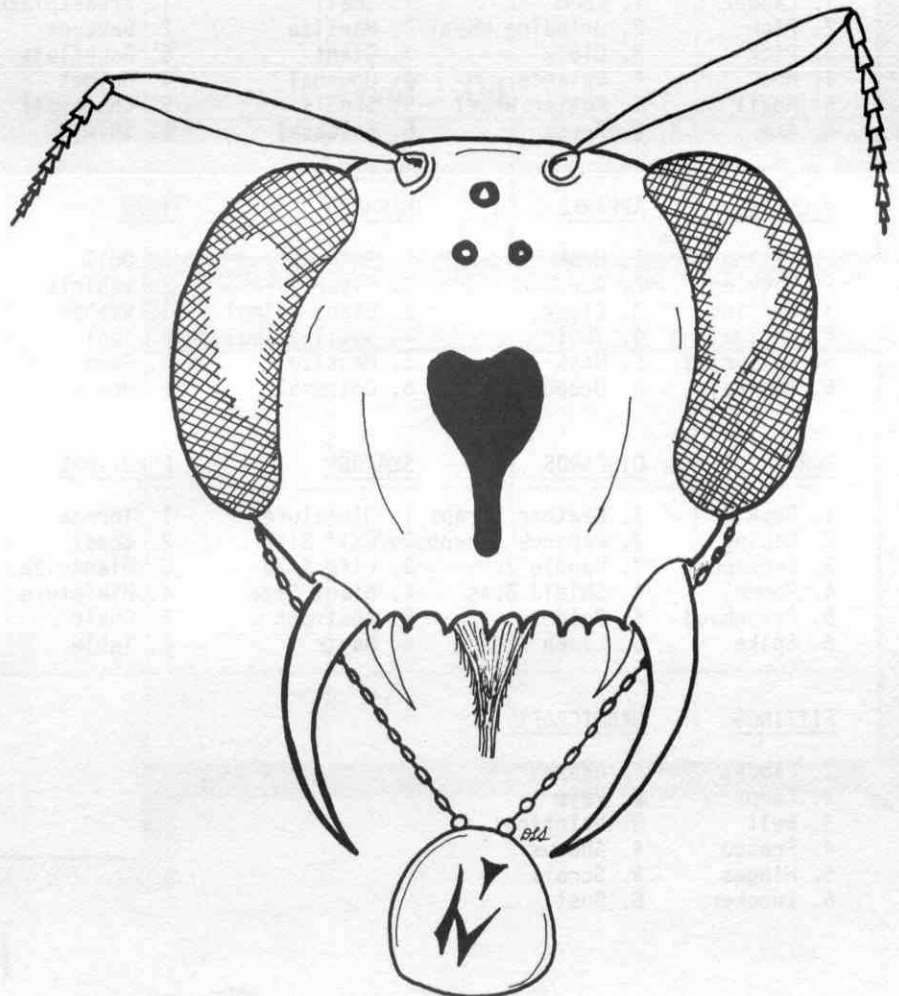
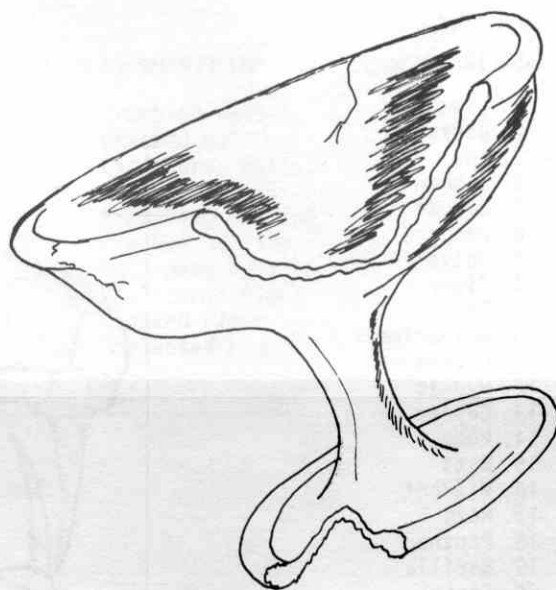
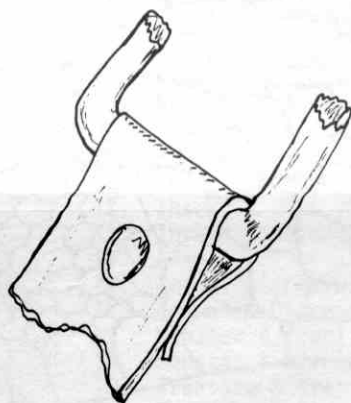

Table 20: FINDS



1. Tools
2. Machines
3. Skeletons
4. Armor
5. Weapons
6. Containers
7. Utensils
8. Apparel
9. Harness
10. Toys
11. Optics
12. Tome
13. Parts
14. Discards
15. Statues
16. Furniture
17. Engravings
18. Idols
19. Fittings
20. Handicraft

TOOLS

1. Ladder
2. Plow
3. Pick
4. Hoe
5. Anvil
6. Axe

MACHINES

1. Loom
2. Grinding Wheel
3. Clock
4. Balance
5. Potter Wheel
6. Press

SKELETONS

1. Small
2. Mansize
3. Giant
4. Unusual
5. Skulls
6. Colossal

ARMOR

1. Breastplate
2. Greaves
3. Gauntlets
4. Helmet
5. Chainmail
6. Shield

WEAPONS

1. Dagger
2. Scimitar
3. HandAxe
4. Spear
5. Bow
6. BattleAxe

CONTAINERS

1. Barrels
2. Urns
3. Trunks
4. Jars
5. Bottles
6. Boxes

UTENSILS

1. Eating
2. Digging
3. Writing
4. Navigating
5. Measuring
6. Musical

APPAREL

1. Hauberk
2. Boots
3. Cloak
4. Tunic
5. Mask
6. Breeches

HARNESS

1. Swimmer
2. Flyer
3. Giant-animal
4. Small-animal
5. Mansize
6. Colossal

TOYS

1. Doll
2. Vehicle
3. Weapon
4. Tool
5. Game
6. House

OPTICS

1. Monocle
2. Spectacles
3. Spyglass
4. Mirror
5. Colored Pane
6. Periscope

TOME

1. Lexicon
2. Scroll
3. Manual
4. Tablet
5. Book
6. Codex

PARTS

1. Buckle
2. Lacing
3. Crossbar
4. Pommel
5. Arrowhead
6. Spike

DISCARDS

1. Leather Scraps
2. Papyrus Scraps
3. Handle
4. Shield Boss
5. Pole
6. Linen Scraps

STATUES

1. Miniature
2. Half Size
3. Life Size
4. Giant Size
5. Abstract
6. Magic

FURNITURE

1. Throne
2. Chest
3. Giantsize
4. Miniature
5. Chair
6. Table

ENGRAVINGS

1. Battlescene
2. Coronation
3. Punishment
4. Religious
5. Romantic
6. Curse

IDOLS

1. Stone
2. Plaster
3. Metal
4. Wood
height:1-20"

FITTINGS

1. Faucet
2. Lamp
3. Bell
4. Fresco
5. Hinges
6. Knocker

HANDICRAFT

1. Basket
2. Vase
3. Painting
4. Abacus
5. Scroll
6. Bust

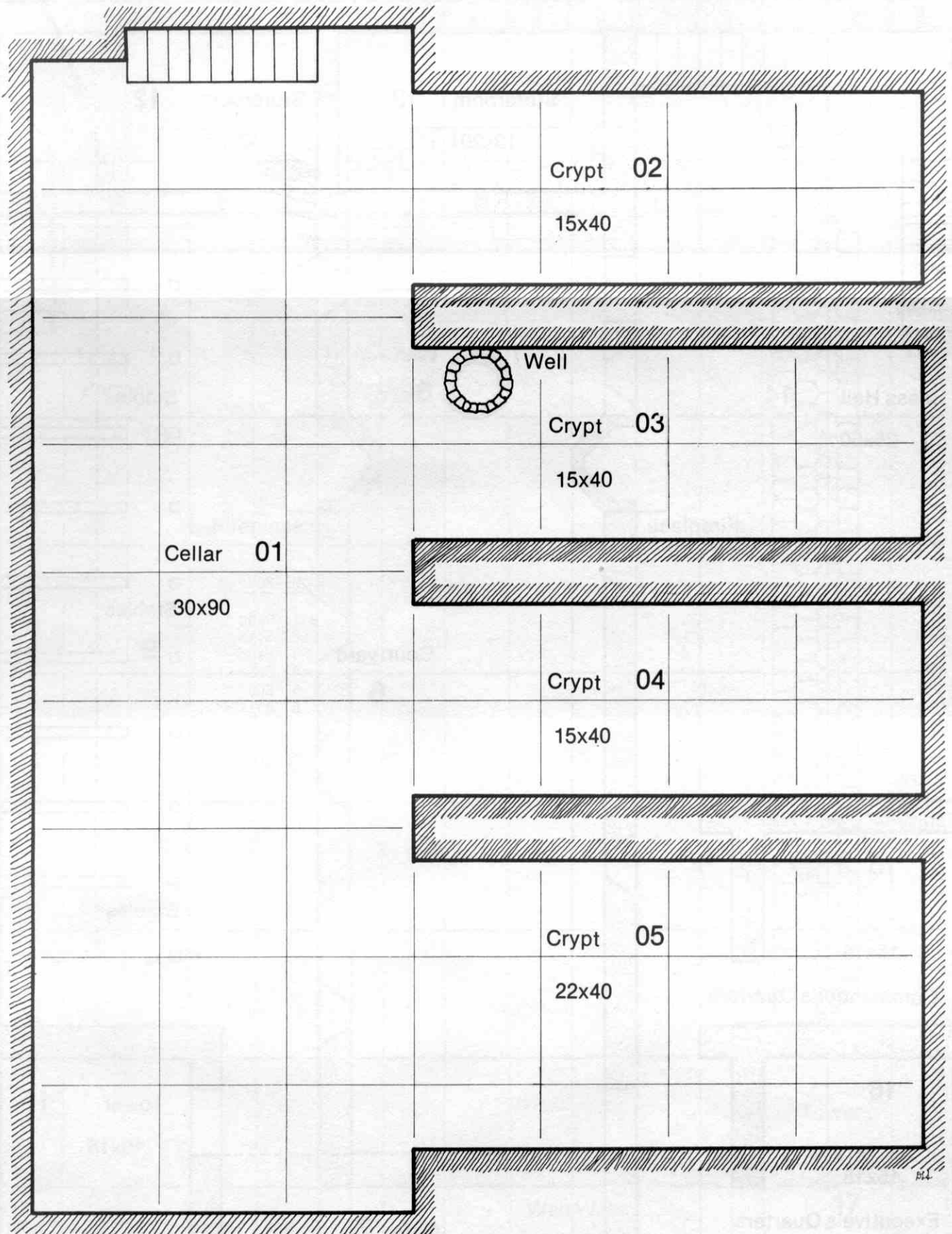

Basement Level

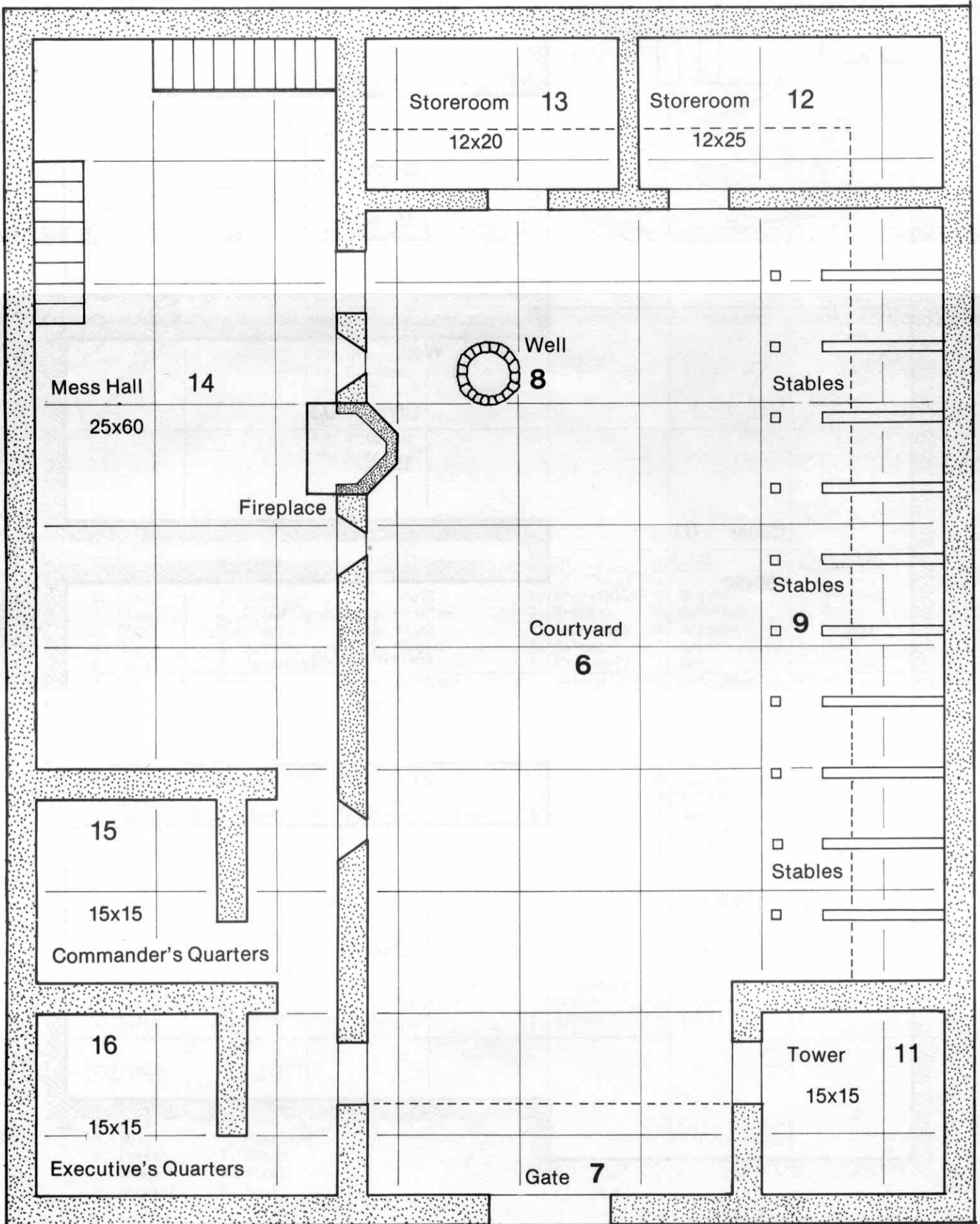

Ground Floor

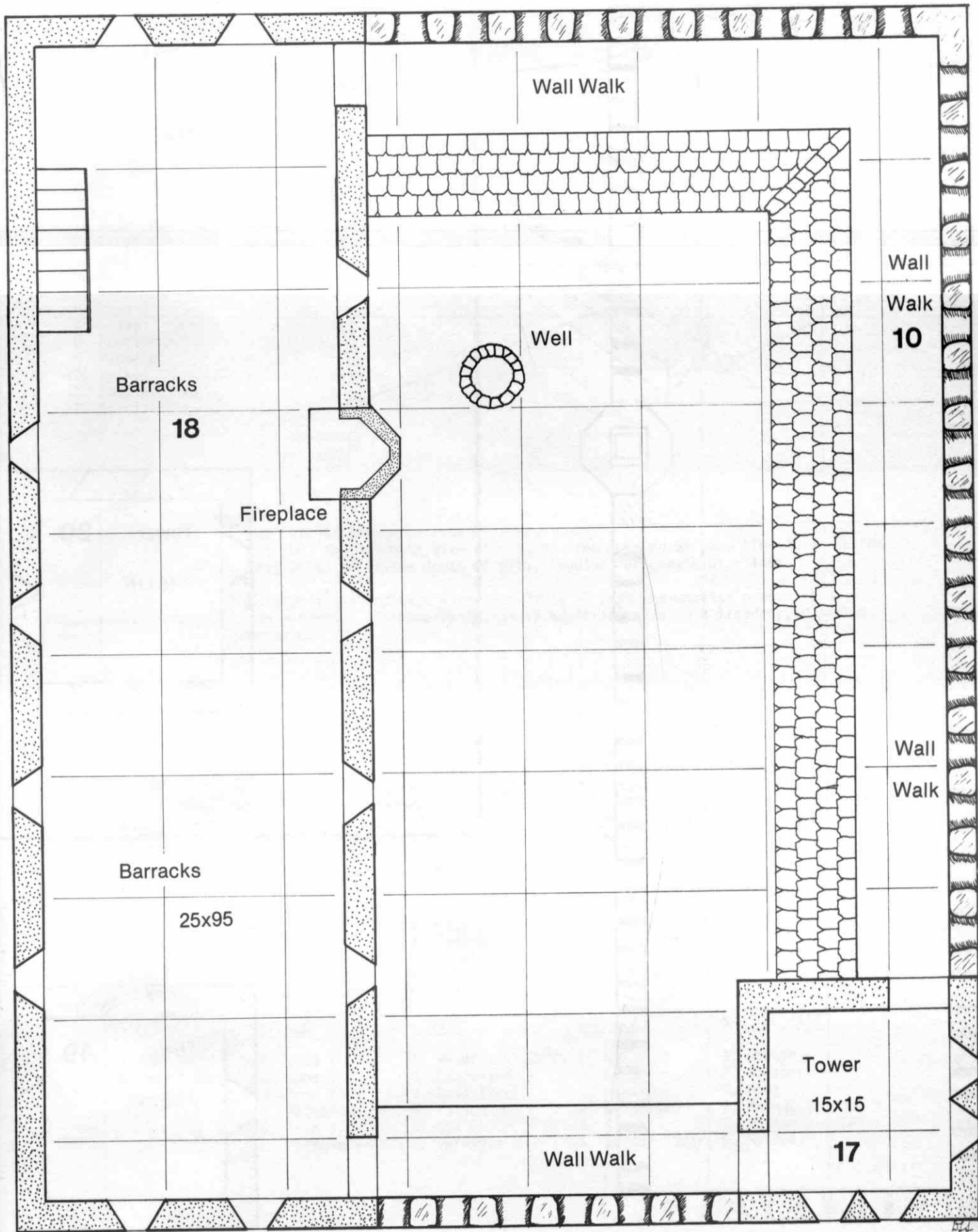

First Floor

PROOF FLOOR

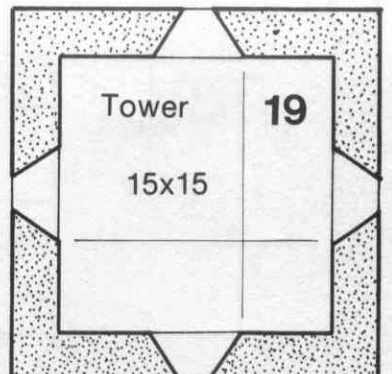
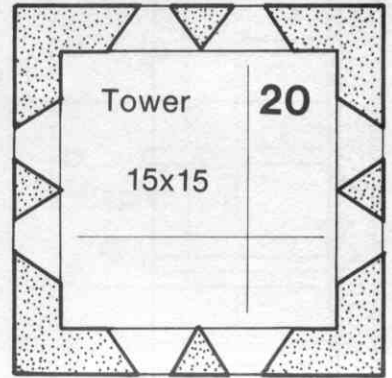
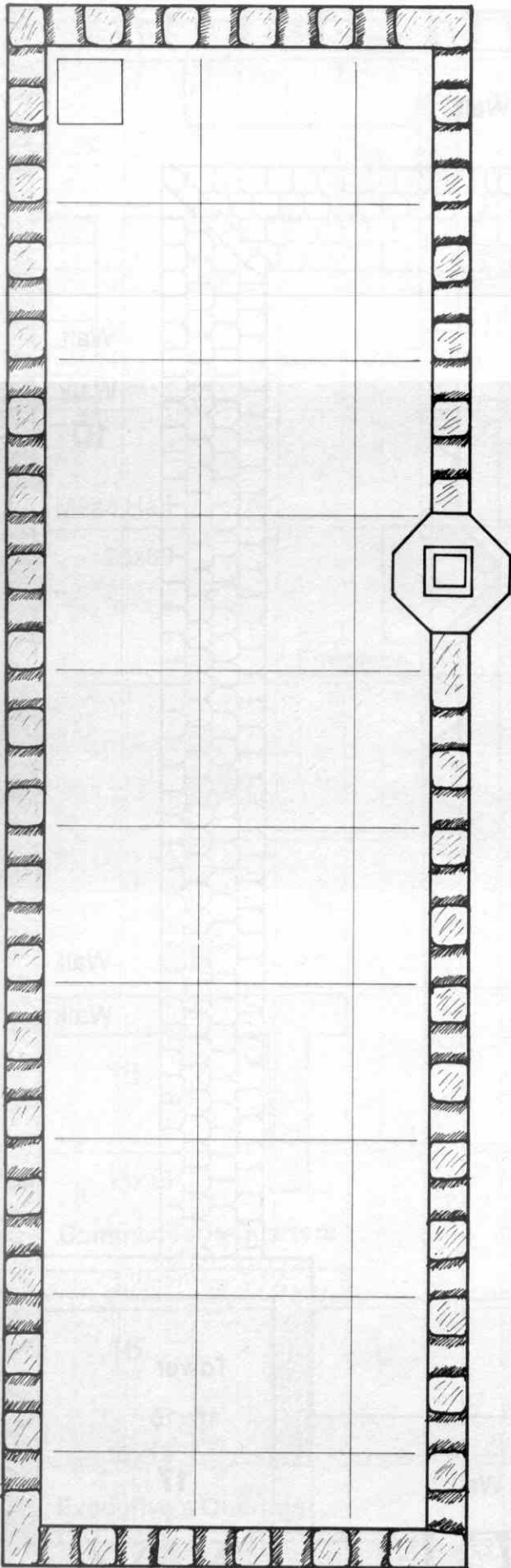

Tower Floors

Table 21: TRAPS

TRAPS

1. Cage Trap
2. Plain Pit
3. Deadfall
4. Gas
5. Snare
6. Liquid
7. Slide
8. Monster
9. Missile
10. Spikes
11. Special Trap
12. Special Pit

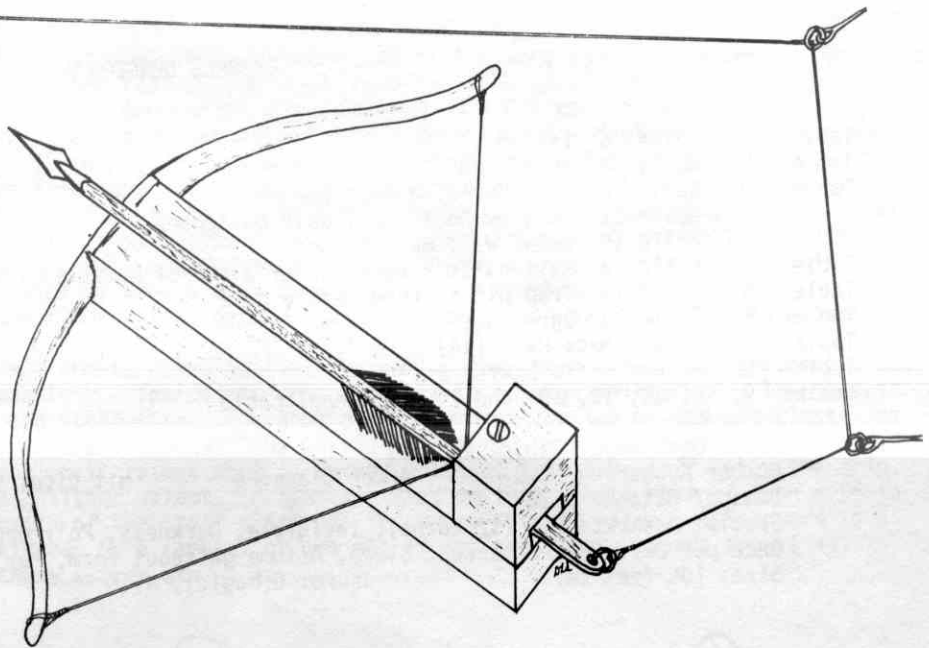

Roll D12 to determine type of Trap.
 Roll D6 to determine size of pit, or area covered by gas, liquid, or spikes.
 Roll D6 to determine depth of pits, liquids, or Length of slides.

Monster traps indicate a roll on Table 17 with the monster generated obtaining surprise at close range, as if appearing through a trapdoor or secret passage.

<u>SIZE</u>	<u>DEPTH</u>	<u>TRAPDOORS</u>	<u>SPECIAL PIT</u>
1. D6	1. 10'	1. Wood 1" Thick	1. Teleport
2. 2-D6	2. 20'	2. Wood 2" Thick	2. Trap
3. 3-D6	3. 30'	3. Stone 4"	3. Illusion
4. 4-D6	4. 40'	4. Reinforced Wood	4. Geas
5. 5-D6	5. 50'	5. Iron 1/4"	5. Another Pit
6. 6-D6	6. 60-360'	6. Iron 1/2"	6. Magical

<u>CAGE</u>	<u>DEADFALL</u>	<u>SNARE</u>	<u>SLIDE</u>
1. Wood	1. Wood (D6)	1. Noose	1. To Snare
2. Grating	2. Wood (2-D6)	2. Mesh Net	2. To Liquid
3. Iron Box	3. Stone (3-D6)	3. Canvas	3. To Monster
4. Crystal	4. Block (5-D6)	4. Tangle	4. To Pit
5. Stone	5. Iron (6-D6)	5. Webs	5. To Trap
6. Prismatic	6. SpikedIron (8-D6)	6. Chains	

<u>MISSILE</u>	<u>SPIKES</u>	<u>LIQUID</u>	<u>GAS PIT</u>	<u>SPECIAL TRAP</u>
1. Arrows D6	1. Wood 1'	1. Water	1. Blinding	1. Ambush
2. Arrows 2-D6	2. Wood 3'	2. Quicksand	2. Laughing	2. Teleport
3. Poison D4	3. Iron 1'	3. Acid (2/r)	3. Poison	3. Hook
4. Spears D6	4. PoisonedWood 1'4.	4. Potion	4. Nauseous	4. Magnet
5. C-Bolts D4	5. Iron 3'	5. Oil	5. Sleep	5. Poison Needles
6. C-Bolts D8	6. PoisonedWood 3'6.	6. Paralyze	6. Shrink 10%/r	6. Magical

EXAMPLE DUNGEON A

Table	1 - Roll#	5	Island
Table	2 - Roll#	2	Abandoned
Table	3 - Roll#	5	Main Building Roof Burned
	Roll#	11	Stables Roof/ Wall Walk Collapsed
	Roll#	15	Gate/ Wall Walk Burned
Table	4 - Roll#	12	Wall built across center width of Barracks (18), doorway in middle
Table	5 - Roll#	11	Trap pit in road before gate
Table	6 - Roll#	20	Ogre Mage
Table	7 - Select	Mess Hall (14)	
Table	8 - Alignment	is Lawful Evil	
Tables	9, 10, 11, 12, 13, and 14	-	Not Applicable

Ogre Mage (Japanese Ogre)

Number Appearing: 1-6 Armor Class: 4 Hit Dice: 5+2
 Damage/ Attack: 1-12
 Special Attacks: Fly (12 turns), Invisible, Darkness, Polymorph to human
 Once per Day: Charm person, Sleep, Assume gaseous form, Ray of cold
 Size: 10½ feet tall Treasure: G(magic), R, S

With the above basic information generated by random means, a Judge is ready to start generating an adventure. "Island" and the relative rareness of the "Japanese Ogre" immediately lead to the question "How did they get there?" The most obvious answer that comes to mind is "by ship." This is enough to start off the scenario as follows:

"Several months ago after an especially fierce storm, a strange ship was spotted beached on the Isle of Zenla. A passing ship captain said 'It was large and squarish-looking with the remains of a wierd rig on its masts. I caught a glimpse of someone on board who looked a lot bigger than a normal man.'

In the past several weeks, fishing boats have disappeared in the vicinity and at least one merchant ship is suspected to have vanished here also. A costal trader reports that there is no shipwreck visible on the beach but the old abandoned fort on the north tip of the island shows signs of activity. Since any sort of hazard to the free passage of trade would be ruinous to our business, as head of the Merchants Guild of our fair city, I am empowered to offer a liberal reward for accurate information on this menace. Even greater rewards will be forthcoming if your party can destroy this unknown menace."

A small coaster is provided with an expert crew and they land the party at night a mile or so down the coast from the fort. A rendezvous and a set of signals are arranged to contact the boat again. The party is now alone as the boat rows quietly out into the night.

What has happened is that a junk full of Ogre Mage offended a local Godling while returning from a raid for loot and slaves. The Godling called a storm, damaged the ship, and threw it far off course. During the storm and the subsequent shipwreck on the Isle of Zenla, many of the slaves were killed and much of the loot was lost. Some of the Ogre Mage were also killed. The chief Ogre Mage has had the ship hidden and repairs started. However; if he were to return after having lost so many slaves and so much loot, he would loose much prestige or "face". The chief Ogre Mage, Hashitogo by name, is determined to recoup his position by preying on the local shipping traffic.

Hashitogo has moved all his slaves into the old abandoned fort at the north end of the island. The junk is anchored in a nearby cove. So that his relatively few remaining crew do not have to waste their time in guarding their loot, he has placed it in the underground portion of the fort and surrounded it with traps. His crew are living in the Mess Hall(14) and for ease of access have knocked the top of the door out up to 10 feet. The slaves are kept chained in the old Storerooms (12&13). An Ogre keeps watch from the highest level of the tower. All of the Ogres have been carefull to appear to anyone visiting the island in a polymorphed human form to retain surprise as long as possible.

Room 01 Cellar, At the very foot of the stairway is a trapdoor, 10 feet square and 10 feet deep. (On Table 21 a two was rolled, locating the trap at the foot of the stair required a 10 by 10 foot size and a one was rolled on a D6 to indicate a 10 foot depth.) Another trap was desired so a D12 was rolled with a result of 11 - Special Trap. On the Special Trap Chart a D6 was rolled with a result of 6 - Magical. Clearly a non-standard type of trap was called for. Therefor, 20 feet down the Cellar from the foot of the stairs, sitting in the middle of the floor is a 1 foot iron cube. Stretching from the box and attached to the walls by little blobs of wax are fine silver wires, very difficult to see in the torchlight. Anyone touching one of the wires with a metal weapon or with any part of the body recieves one D6 of damage from lightning bolts. Smashing the box(it takes 20 hit points to destroy) will eliminate the trap. Anyone touching the box or hitting it with a metal weapon recieves one hit point of damage each time they hit or touch the box.

Two small leather bags lie on the floor 2 feet beyond the iron cube. Each bag has 100 gold pieces in it and a poisonous centipede.

At the far end of the cellar are 4 chests piled against the wall. The three top chests are empty, the bottom chest has a poisoned trap on the lock. Inside the trapped chest is a large velvet bag. The objects within are 4 in number, 4 foot long, and staff-like. The ornate cord holding the top of the bag closed has little metal burs within it. These burs are poisoned. The staffs are of two types, both slightly curved, and have handgrips of woven cord with a small raised ring of carved wood set into the staff below the grip. Two staffs look like bamboo, two like polished walnut. A special twist on this ring(a roll of 1 on a D6 to discover the trick) and the lower portion of the staff slips off to reveal a sword blade. This sword is a Katana, a Japanese Longsword. When wielded by a samurai or one who is trained, these swords are +1 +1. When wielded by one not so trained, these swords are -1 -1.

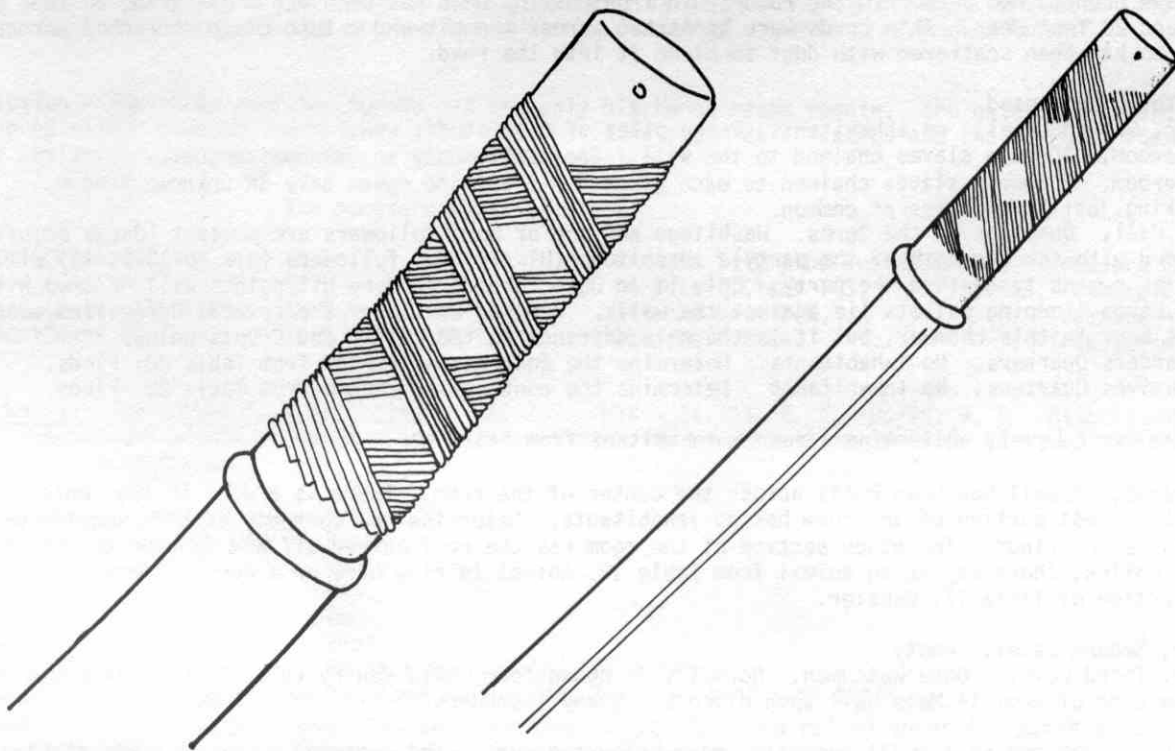

Room 02 Crypt, Just inside the arched entrance is a thin cord lying in the dust of the floor. Anyone stepping over the cord triggers a shower of tiny poison darts from the ceiling. Each character in the crypt or at the entrance must roll their dexterity or under on a D20 to avoid being hit. Those failing will be hit with one D4 of darts, each dart causing one hit point.

At the far end of the crypt against the wall are three large wicker chests. Two are empty. The third has 4 small carved and lacquered wooden boxes in it. Two are ordinary boxes. One is a "Box of Holding", able to contain 1,000 gold pieces. The last is a "Box of Devouring". These 6 by 6 by 3 inch boxes are all physically identical.

Room 03 Crypt, Another iron cube sits on the floor just inside the entrance with its web of silver wires stuck to the wall. This box is defective and will give out 2 points of damage the first time either it or the wires are touched. Thereafter it becomes inert. 10 large casks are stacked at the end of the crypt. They contain rice wine. One of the casks has a tap in its side. The tap has a poison needle on it. Drinking any of the wine in this cask will cure 2 hit points of damage on a person the first time they drink. No further amounts of wine will cure anything, only produce drunkenness.

Room 04 Crypt, An iron cube sits on the floor with its web of silver wires attached to the walls. This cube is completely inert and can cause no damage. One foot beyond the cube is a trip cord. Touching this cord releases a flight of crossbow bolts from a false chest in each corner of the room. Anyone in the entrance must roll their dexterity or under on a D20 to avoid being hit. If hit each person will take one D4 of damage.

At the far end of the crypt are a pile of small leather bags. Two of the bags have 100 gold pieces in each. The other 10 bags have fist-sized round rocks in them. Each rock is a geode, hollow and filled with jeweled crystals. Each geode has a 5% chance (1 on a D20) of containing an emerald worth 1,000 gold pieces. Otherwise a geode is worth 10 gold pieces. There are 10 geodes per bag.

Room 05 Crypt, An iron cube with its wire web occupies the arched opening to the crypt. The wires are dead, but striking the box will cause it to break open and release a poison gas. All characters within 10 feet must save by rolling their constitution or less on a D20. If failing, their constitution is reduced by a D4 permanently.

At the far end of the crypt are 6 small iron chests. Each has poison trapped locks. Three chests are empty. Two are quite heavy. They are completely filled with irregular blocks of green, yellow, brown, and white soapy textured stone. These stones are uncarved raw jade and each chest has a worth of 10,000 gold pieces. The last chest contains twelve carved statues of jade, each statue is worth 5,000 gold pieces.

Above ground the old fort shows signs of long neglect. The roof of the stables has collapsed and the stones of the wall walk have fallen into the rubble. The wall at this point has collapsed to half of its normal height. Half of the roof of the Main Building has burned and only blackened beams remain. The doors of the Gate have been burned away. In the roadway in front of the Gate has been dug a pit trap, 20 feet by 20 feet wide and 20 feet deep. Thin cords were stretched across the pit and a thin cloth stretched across them. The cloth has been scattered with dust to blend it into the road.

Room 09 Stables, Collapsed

Room 11 Tower, Ground Level, no inhabitants, large piles of food stuffs

Room 12 Storeroom, 10 male slaves chained to the wall. They speak only an unknown tongue.

Room 13 Storeroom, 6 female slaves chained to each other. All but one speak only an unknown tongue, the last speaking just a few words of common.

Room 14 Mess Hall, Quarters of the Ogres. Hashitogo and one or more followers are present (Judge adjust number in accord with the strength of the party). Hashitogo (HTK 35) and followers (HTK 20-18-20-24) will try to appear as humans to confuse the party. Only if an Ogre takes 5 or more hit points will he drop his human shape. Large sleeping pallets lie against the walls. Hung on wall pegs are several Ogre-sized weapons. No treasure is kept in this chamber, but it is the only entrance to the Cellar and Crypts below.

Room 15 Commanders Quarters, No inhabitants. Determine the contents at random from Table 20: Finds.

Room 16 Executives Quarters, No inhabitants. Determine the contents at random from Table 20: Finds.

Room 17 Tower, First Level, Determine a random inhabitant from Table 19: Insect.

Room 18 Barracks, A wall has been built across the center of the room. There is a door in the center of the wall. The nearest portion of the room has no inhabitants. Determine the contents of this section at random from Table 20: Finds. The other section of the room has the roof burned off and is open to the sky. At the Judges option, there may be an animal from Table 18: Animal lairing here or a monster from the appropriate section of Table 17: Monster.

Room 19 Tower, Second Level, empty

Room 20 Tower, Third Level, Ogre Watchman. Normally in human form, this sentry (HTK 25) will fire a whistling arrow into the door of Room 14 Mess Hall upon discovering any intruders.

The junk is anchored in a small concealed cove below the fort. The captured crews of three fishing boats and a small merchant vessel are locked in the hold. Two Ogres are on guard (HTK 17-22) and have polymorphed themselves into the appearance of old fishermen. On the beach are the remains of the captured vessels, torn down to provide repair materials for the junk.

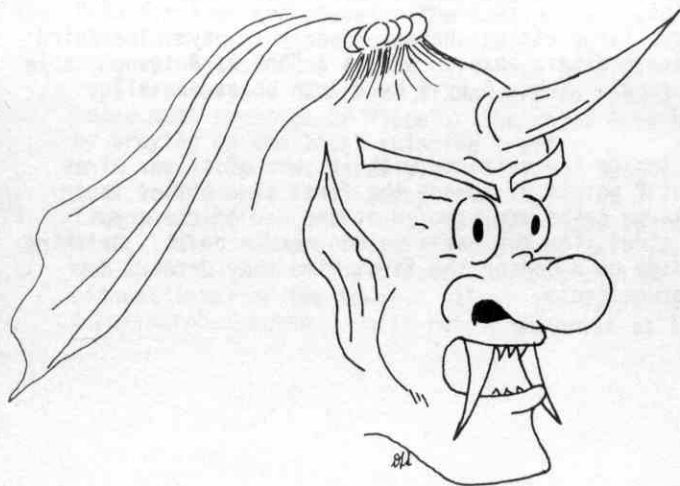

EXAMPLE DUNGEON B

- Table 1 - Roll# 11 Rocky Eminence
- Table 2 - Roll# 1 Ancient Ruin
- Table 3 - Roll# 1 Tower Roof Burned
 - 5 Main Building Roof Collapsed
 - 14 Gate/Wall Walk Collapsed
 - 16 Well Collapsed
- Table 4 - Roll# 4 Stone Tower built on nearby prominence (600 yds. to SW)
- Table 5 - Roll# 1 Escape tunnel dug from crypt 02 to ruined tower 600 yds. to SW
- Table 6 - Roll# 19 Vampire
- Table 7 - Roll# 5 Crypt 05
- Table 8 - Not needed Vampire is Chaotic Evil
- Table 9, 10, 11, 12, 13, 14 Unnecessary
- Table 17 has Ghouls
- Table 18 has Wolves and Bats

Having rolled the above basics for an adventure party which contains at least several very high level characters, a Judge might choose to elaborate the scenario in the following fashion.

"The members of your party have assembled at the request of a local magistrate. The official has received reports of activity in the ruins of old Fort T'Karg. Sheep and cattle in the vicinity have been disappearing and within the last two nights several local farmers and herders have vanished. The peasants are very frightened and two claim to have glimpsed a large dark flying creature late one night. You are requested to investigate and resolve the situation. Liberal rewards have been offered."

Description - The tower roof has burned off and only blackened beams remain. The gates are smashed open and lie rotting on either side of the gateway. The main building roof has collapsed and the barracks room (18) is open to the sky and littered with rubble. The well has collapsed.

The Monsters Statistics are:

Vampire (Crypt 05)	AC 1	HD 8+3	Attacks 5-10 plus Energy Drain	Treasure F
Ghouls 4 (Crypt 01)	AC 6	HD 2	Attacks 2 Claws 1-3, Paralyzation,	Treasure B,T
Wolves 8 (Mess Hall 14)	AC 7	HD 2+2	Attacks Bite 2-5,	Treasure - None
Bats 50 (Tower 20)	AC 8	HD 1/2	Attacks - None,	Treasure - None

8 Wolves den in the Mess Hall (14) AC 7 HTK - 14, 13, 6, 5, 10, 16, 9, 8 Attacks: Bite - 2-5
Bones and scraps of weapons and harness litter the room, nothing of value here; wolves may be summoned to 05 by Vampire.

- Commanders Quarters (15) Empty
- Executives Quarters (16) Empty
- Storeroom (12) Empty
- Storeroom (13) Empty
- Stables (9) Empty
- Tower (11, 17, 19) Empty
- Tower (20) 50 Bats AC8, HD 1/2, Attacks-nil

Unable to attack but may be summoned by Vampire, serve as confusion spell.

Underground - An escape tunnel has been dug from Crypt (02) to a ruined tower 600 yards to the southwest. The entrance is hidden by a thin slab of stone in the northeast corner floor.

- Cellar (01) Empty
- Crypt (02) 4 Ghouls AC 6 HTK 9, 14, 8, 13 Attack 2 Claws 1-3, Fangs 1-6, Paralyzation

Two large wooden chests are against the wall on either side of the crypt, a Ghoul is seated on each chest and covered in a dusty shroud. They are difficult to see - obtain surprise on 1-4.

- Chest 1 - Empty
- Chest 2 - 1,000 gold poison trap on lock
- Chest 3 - 100 platinum
- Chest 4 - 1 gem (w/500 gold) in false bottom

The Ghouls are under the control of the Vampire in Crypt 05.

- Crypt 03 Empty
- Crypt 04 Empty
- Crypt 05 Vampire AC 1 48 HTK Attacks 5-10+ Energy Drain

A Vampire has hidden his coffin in a pile of refuse against the far wall. Several large leather bags are lying in the entrance arch to the crypt. Two of the bags are empty. The third bag has a small wooden case. The case has a poison trapped lock, inside is a jeweled dagger, +3 +3 against undead. Hidden under a loose flagstone is a jar containing 5 emeralds, worth a total of 10,000 GP. Also in the jar are 5 green scorpions.

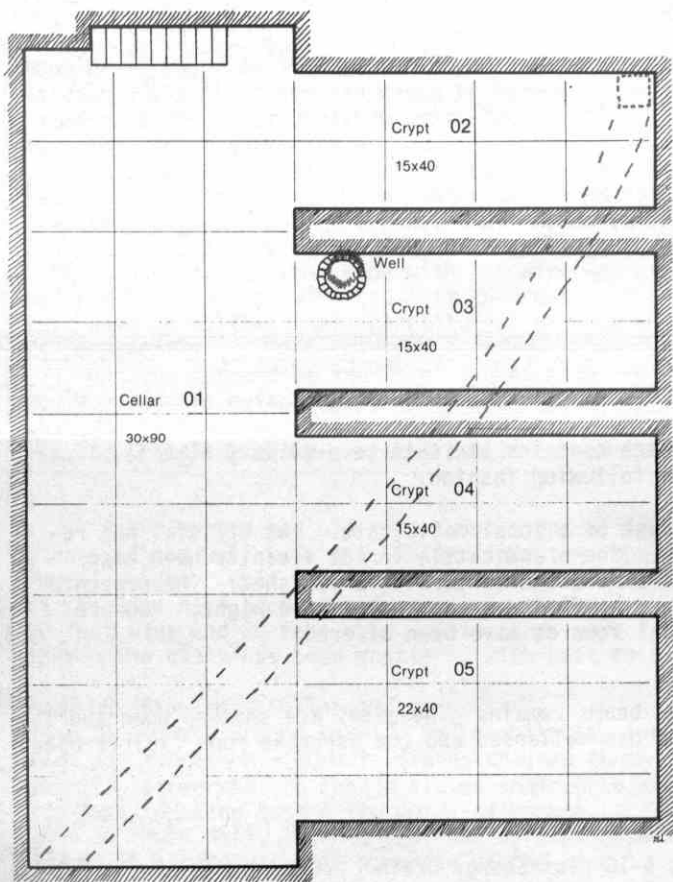

Basement Level

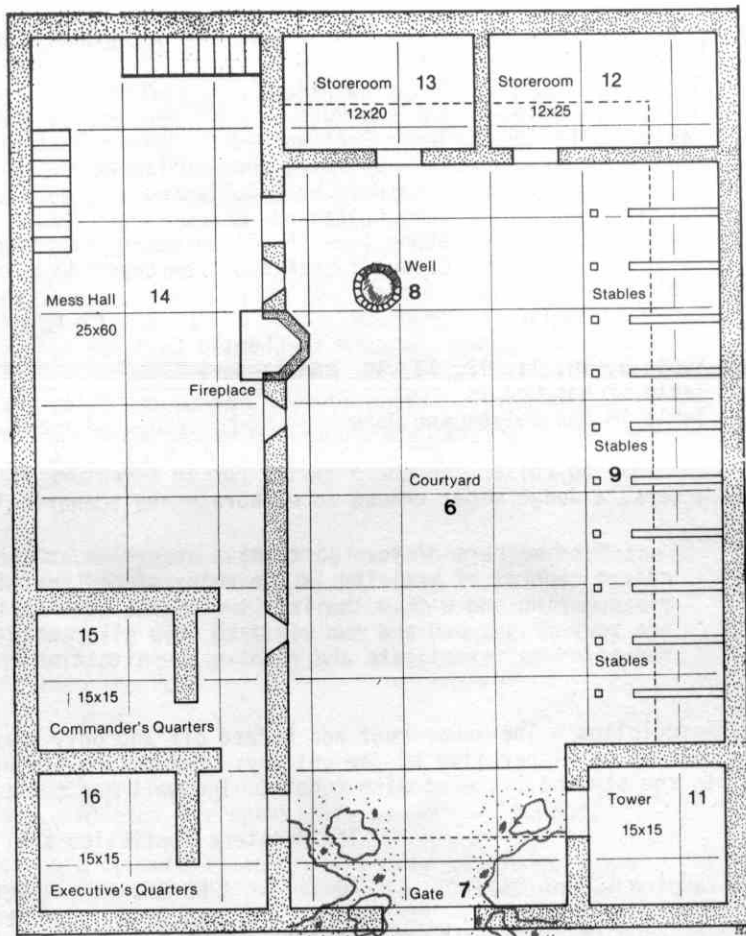

Ground Floor

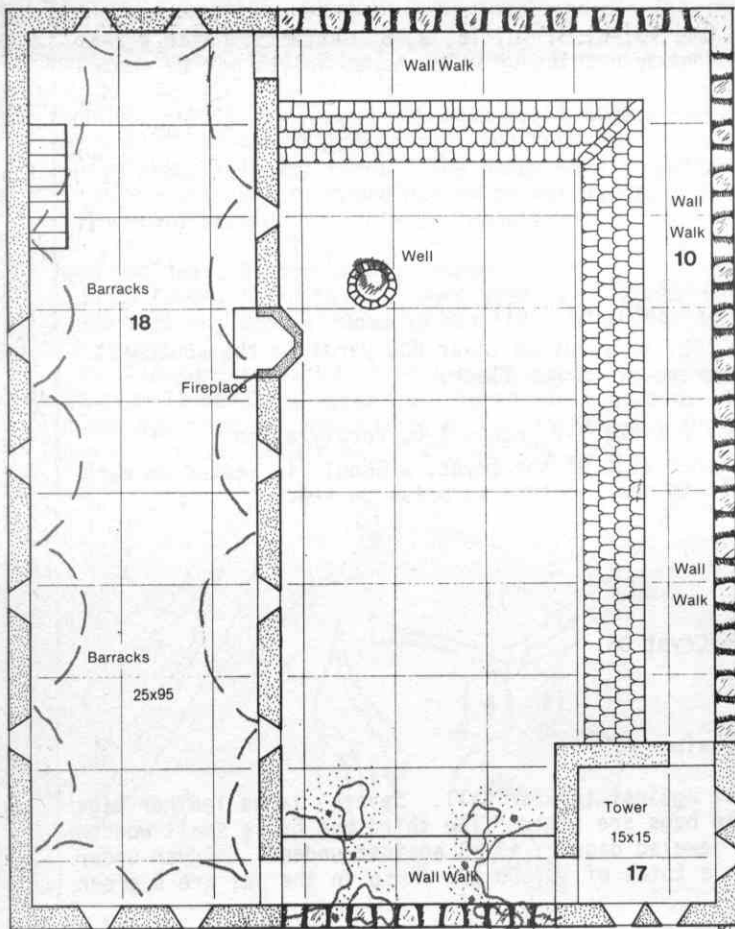

First Floor

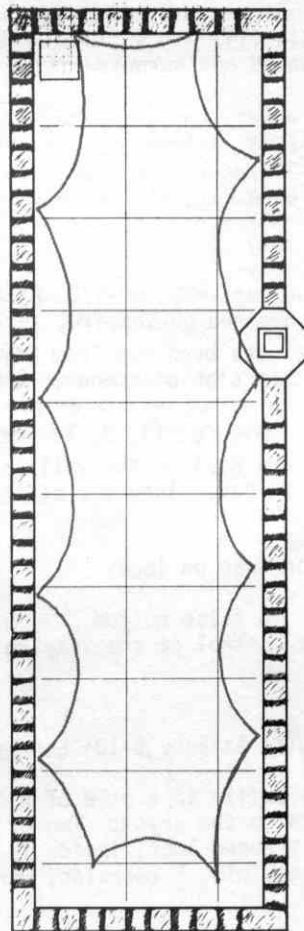

Tower Floors

Example
Dungeon
B

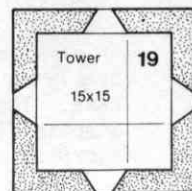
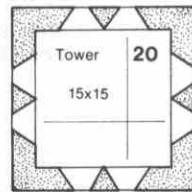

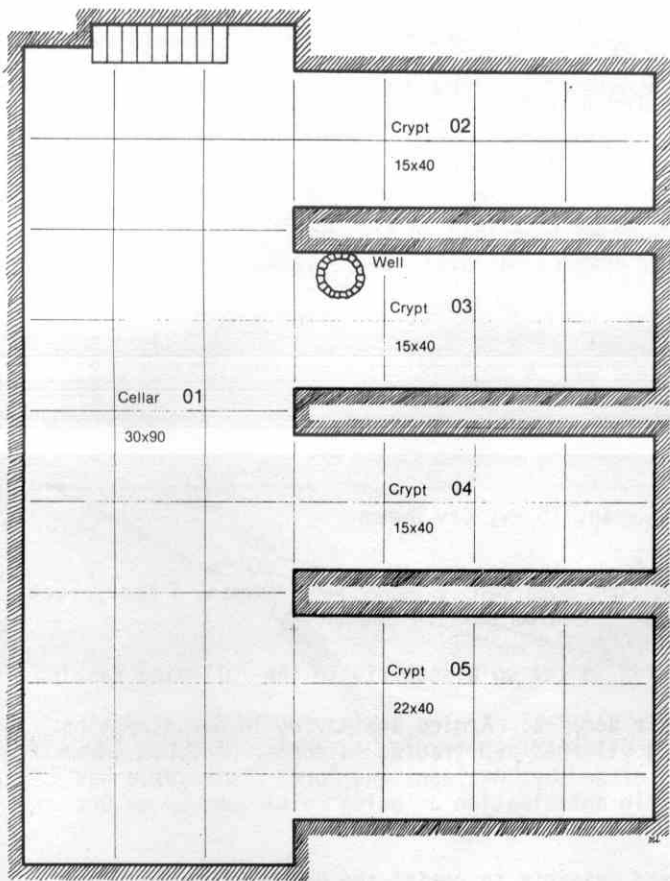

Basement Level

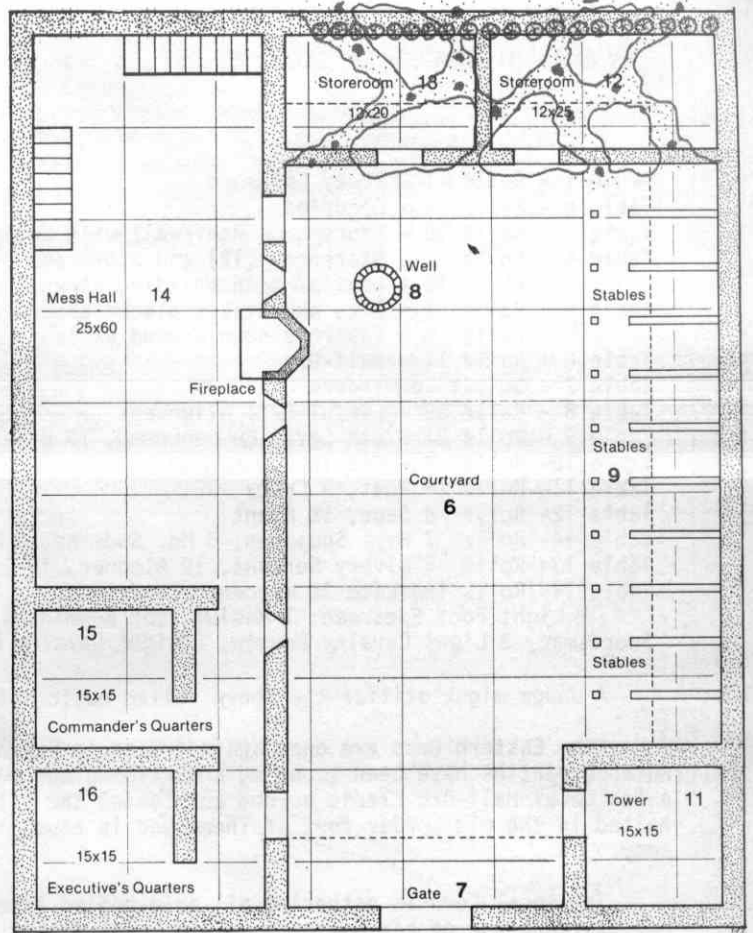

Ground Floor

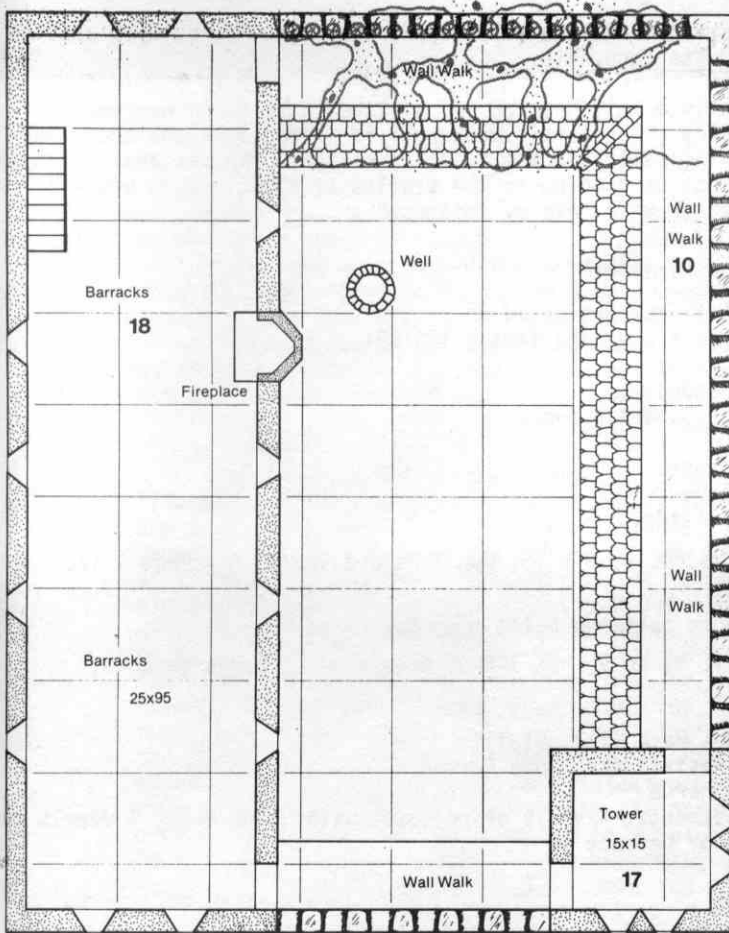

First Floor

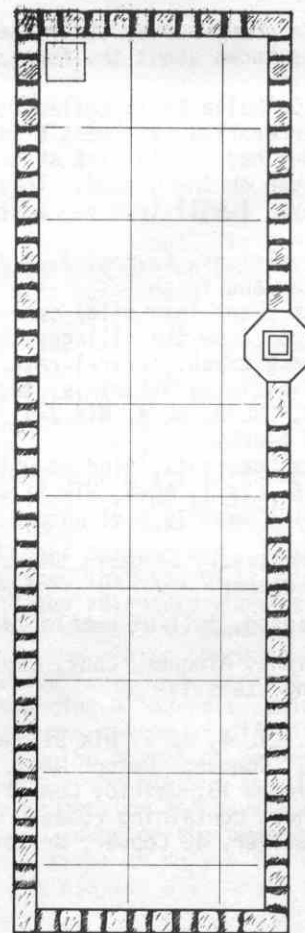

Tower Floors

*Example
Dungeon
C*

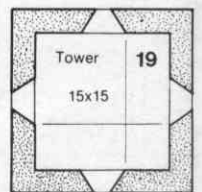
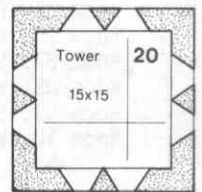

EXAMPLE DUNGEON C

- Table 1 - Roll# 11 - Rocky Eminence
- Table 2 - Roll# 4 - Occupied
- Table 3 - Roll# 10 - Storerooms Roof/wall walk Collapsed
- Table 4 - Roll# 5 - Storeroom (12) and Storeroom (13) combined into 15 X 30 ft. room
Roll# 15 - Roof of main building strengthened to support catapult
- Table 5 - Roll# 7 - Pits and Stakes placed around walls
Roll# 8 - Caltrops sown around walls
- Table 6 - Roll# 11 - Half-Orc
- Table 7 - Select Commanders Quarters
- Table 8 - Roll# 39 - Lawful Evil Alignment
- Table 9 - Roll# 21 - 5th Level (8 Henchmen, 15 Hirelings)
- Table 10- Roll# 9 - Cleric
- Table 11- Roll# 14 Poet, 9 Crony
- Table 12- Roll# 8 Sage, 12 Agent
- Table 14- Roll# 7 Hvy. Spearman, 6 Md. Swdsman, 6 Md. Swdsman, 15 Hvy Cav Bwman
- Table 13- Roll# 5 Livery Servant, 19 Almoner, 15 Cook
- Table 14- Rolls indicate 12 mercenary Warriors
1 Light Foot Spearman, 1 Medium Foot Bowman, 2 Heavy Foot Spearmen, 1 Heavy Foot Bowman, 1 Heavy Foot Swordsman, 2 Light Cavalry Bowmen, 2 Light Cavalry Lancers, 2 Medium Cavalry Bowmen

A Judge might utilize the above rolled basic information to set up a scenario in the following fashion.

"The Eastern Orcs are once again trying to expand their domains. Armies are moving in our direction. Advance parties have been scouting and raiding our outlying villages and trading outposts. A force under a 5th Level Half-Orc Cleric burned and looted the villages of Hedeby, Gallwon, and Zora. This force has halted in the old border fort of Thena and is repairing it in anticipation of being reinforced by an Orc army.

The local Lord is gathering all able-bodied freemen and peasants to resist the oncoming armies. He has assigned one of his Captains, a 4th Level fighter, to lead a group of mercenaries to attack the fort. He wants to destroy the occupying force before they can repair the fort and establish an advanced base. Bonuses have been promised for participation as well as half of all loot."

One of the local peasants, captured by the raiders and forced to help repair the fort, has escaped and is now telling the Captain all he knows about the fort and its occupants.

"I saw the evil Cleric, Ca'halla he is called. He is a half-Orc and has at least 6 half-orc henchmen. They have 10 or more human mercenaries, at least 6 cavalry. The fort's back wall is broken down and they made us put up a wall of logs. They had us dig pits around the walls and put in sharp stakes. The mercenaries threw down many little iron stars down on the ground. They kept us tied up in the stables at night. Last night I loosened my ropes and got away. I will lead you back to them to help my friends."

- Room 01, Cellar - bags of provisions, several kegs of wine, litter & trash
- Room 02, Crypt - Empty, litter and trash
- Room 03, Crypt - Empty, trash swept into pile, several flagstones pried up
- Room 04, Crypt - Chests of loot from the villages, goods & clothing (total 120 GP)
- Room 05, Crypt - Empty, litter & trash, several rats
- Room 06, Courtyard - Piles of building Materials, two wagons
- Room 07, Gate - Two Guards CN, LVL 2, AC 4, HTK 7-4, Wpn Spears & Sword
- Room 08, Well - Tools stacked nearby
- Room 09, Stables - 8 prisoners, peasants, tied up with ropes
- Room 10, Wall Walk - Sentry LE, LVL 1, AC 5, HTK 3, Wpn Bow
back portion of wall walk a hastily made wooden palisade.
- Room 11 Tower Base Level - Mercenary Sergeant CN, LVL 3, AC 3, HTK 13, Wpn 2-Handed Sword, Paychest - 120 Gold, 50 Silver, 90 Copper
- Room 12 Storeroom
- Room 13 Storeroom Roof collapsed, full of rubble, Wooden palisade built over top.
- Room 14 Mess Hall Lvery Servant, Almoner, Cook, CN, LVL 1, AC 9, HTK 3-4-3, Wpns - none, Rough benches, food storage, cooking utensils
- Room 15 Commanders Quarters
Cleric Ca'halla, LE, LVL 4, AC 2, HTK 21, Wpn - Mace +1+1, Flail.
Spells. Bless/Curse, Command, Detect Magic, Resist Fire, Hold Person
ST 15, Intell 11, Widdom 13, Dex 10, Con 17, Char 8
Bed, Desk, Chair, Chest containing robes & vestments, 4 vials of polluted water, 250 Gold, 3 Jewels worth 120 Gold, 97 Silver, 42 Copper, Bracers of Defence +1

- Room 16 Executives Quarters Poet, Crony, Sage, Agent CN, LN, CE, LE, LVL 1, AC 9, HTK 2-6-1-6, Wpns Daggers blankets, wineskins, chest with 30 Silver, 57 Copper
- Room 17 Tower First Level 6 Blanket rolls, leather backpacks, cloaks, minor equipment, no one present
- Room 18 Barracks 4 half-orc henchmen, CE, LVL 1, AC 6-6-4-4, HTK 4-4-5-8, Wpn - sword, sword, spear & sword, Bow & Sword Blankets, wine cask (empty), Leather bag with Jewelry worth 50 Gold.
- Room 19 Tower Second Level 5 blanket rolls, leather backpacks, cloaks, minor equipment, 1 Fighter, LVL 1, AC 8, HTK 5, Wpn Spear & Sword
- Room 20 Tower Top Level Watch - LVL 1, AC 6, HTK 3, Wpn Bow & Sword

On Patrol in the vicinity are:

- Hvy Cav Bowman, Half-Orc LVL 1 AC 3 HTK 8 Wpn Bow & Sword
- 2 Light Cavalry Bowmen LVL 1 AC 9 HTK 4-6 Wpn Bow & Sword
- 2 Light Cavalry Lancers LVL 1 AC 8 HTK 5-4 Wpn Spear & Sword
- 2 Medium Cavalry Bowmen LVL 1 AC 6 HTK 7-4 Wpn Bow & Sword

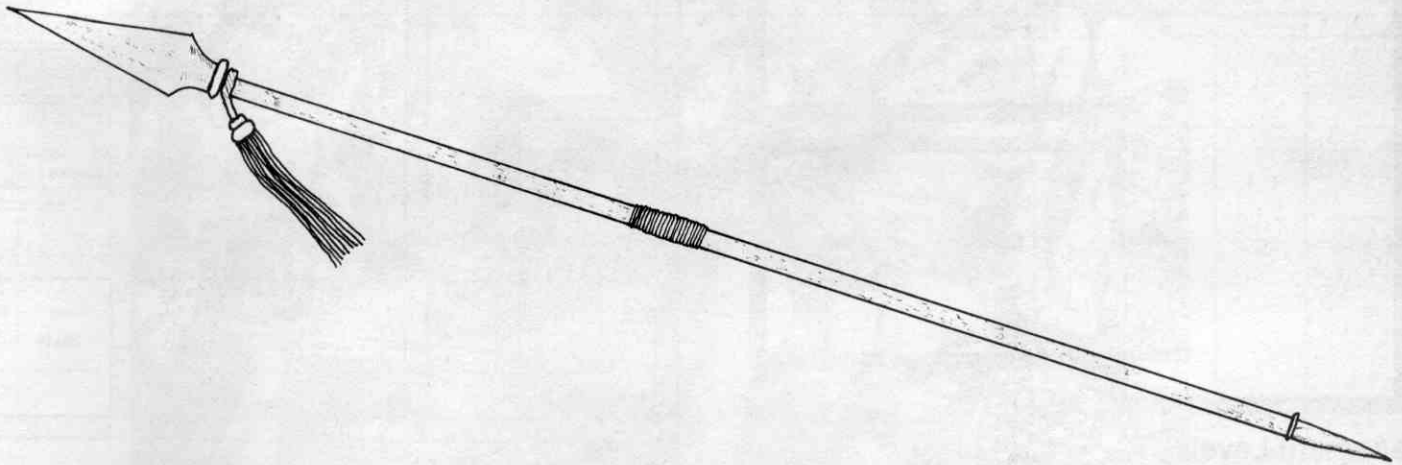

HINTS TO JUDGES

Deliberately give descriptions as vague and general as possible. Many of the men and creatures in the selection are quite adept at resembling something else. It adds greatly to the enjoyment of the "Dungeon Session" if characters must puzzle out precisely what it is they are up against. "Rumors and tales" of the surrounding populace should be enough to give a general hint but should never state exactly what the problem is. Identifying the approximate size and whether it was on the ground or air is the most a peasant could do. Terrified serfs can count only "one, three, many!" Never the less, attitudes and feelings of the local populace are very important in determining the possible alignment of any intruders in the local fort. Adventurers can get a good "feel" of what the opposition is by talking with the local inhabitants.

The descriptions of the sample forts described herein are very cursory and are to be "fleshed out" by the judge. Please adjust them to reflect the tenor of your campaign and add your own traps, creatures, modifications, and ideas. There are spaces left in the table pages so you can add your own tables for use with this playing aid. To introduce a series of frontier forts in a large campaign, it is suggested that you dice up a description very similar to those samples provided and "flesh out" the adventure when it is likely that one will take place in the area. You can often lead the players to partake of an existing set-up by the judicious use of rumors, trails of clues, non-player characters, complaints by the local populace, propositions by cults or organizations, and outright animosity or revenge for the loss of some possession. By introducing a legend alluding to some ancient ruin, some mystery and a reasonable "warning" as to the degree of difficulty to be overcome can be given. In any event, keep in mind that while the threat of permanent loss should be apparent in any adventure...the greatest pleasure for the players and judge of any fantasy role playing campaign is to be had in the orderly progression and development of characters over a long period of time. Do not be a "give-away" judge or the campaign will become boring. Do not be a "Hanging Judge" with overwhelming death traps or only a few will be induced to enjoy your hours of work (if any). Have fun and the players will enjoy themselves in turn.

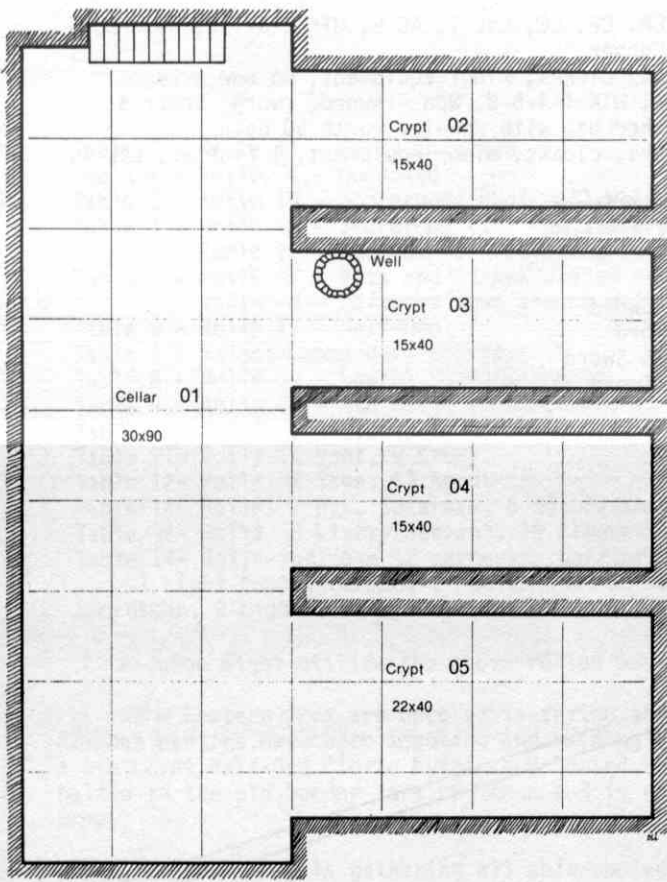

Basement Level

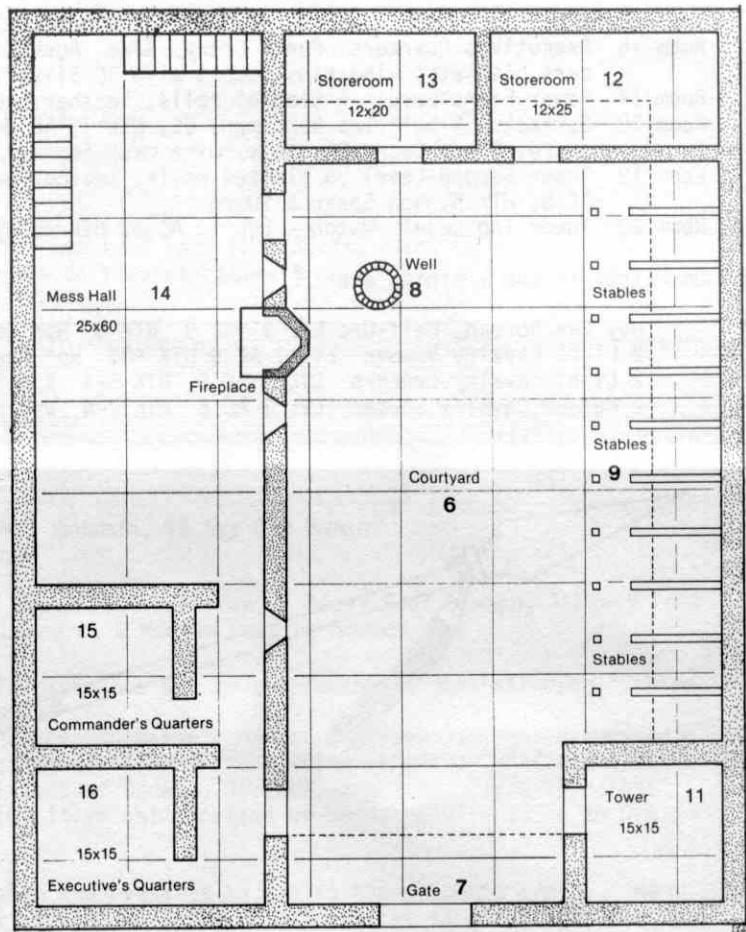

Ground Floor

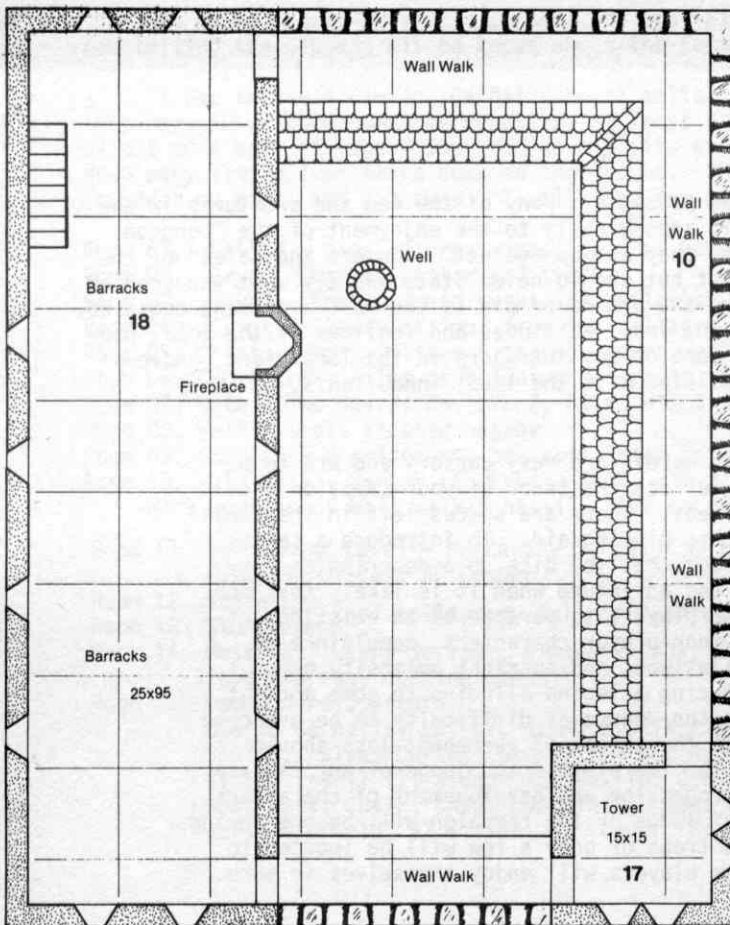

First Floor

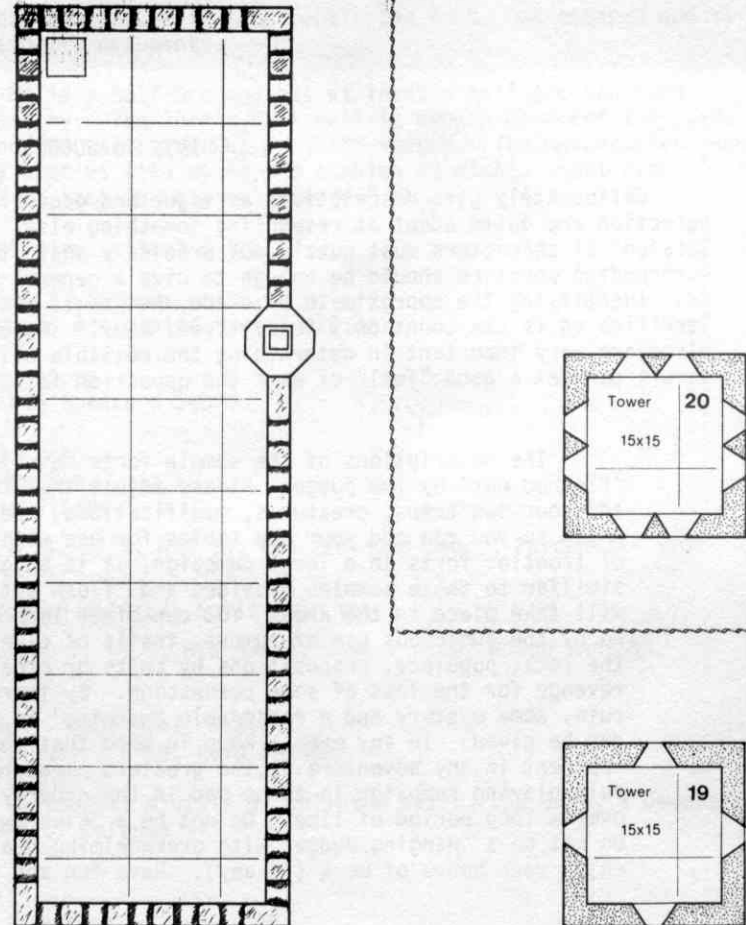

-28- Tower Floors



AYE ME LADDIES!! FIRST THE FRONTIER FORTRESS AND THEN THE CITY STATE!!!!
THE POT BELLED EMPEROR IS TOO FULL OF SWILL TO SEE DANGER UPON HIS DOORSTEP

Judges Guild

Campaign Playing Aids

A World of Fantastic Adventure

